



LIPPERT COMPONENTS, INC.

ELECTRIC REAR STABILIZER JACK OPERATION MANUAL

rev100410

SYSTEM

WARNING!

FAILURE TO ACT IN ACCORDANCE WITH THE FOLLOWING MAY RESULT IN SERIOUS PERSONAL INJURY OR DEATH.

THE LIPPERT ELECTRIC REAR STABILIZER JACK is intended for the purpose of STABILIZING THE REAR END OF THE UNIT. THE USE OF THIS SYSTEM FOR ANY REASON OTHER THAN WHICH IT IS INTENDED IS PROHIBITED BY LIPPERT'S LIMITED WARRANTY AND MAY RESULT IN SERIOUS PERSONAL INJURY OR DEATH.

THE LIPPERT ELECTRIC REAR STABILIZER JACK IS DESIGNED AS A STABILIZING COMPONENT SYSTEM AND SHOULD NOT BE USED TO PROVIDE SERVICE FOR ANY REASON UNDER THE COACH SUCH AS CHANGING TIRES OR SERVICING ANYTHING BENEATH THE UNIT.

LIPPERT COMPONENTS, INC. RECOMMENDS THAT A TRAINED PROFESSIONAL BE EMPLOYED TO CHANGE THE TIRE ON THE COACH. ANY ATTEMPTS TO CHANGE TIRES OR PERFORM OTHER SERVICE WHILE COACH IS SUPPORTED BY THE LIPPERT ELECTRIC REAR STABILIZER JACK COULD RESULT IN DAMAGE TO THE COACH AND/OR CAUSE SERIOUS PERSONAL INJURY OR DEATH.

- BE SURE TO PARK THE UNIT ON SOLID, LEVEL GROUND.
- CLEAR ALL STABILIZER JACK LANDING LOCATIONS OF DEBRIS AND OBSTRUCTIONS. LOCATIONS SHOULD ALSO BE FREE OF DEPRESSIONS.
- WHEN PARKING THE UNIT ON EXTREMELY SOFT SURFACES, UTILIZE LOAD DISTRIBUTION PADS UNDER EACH JACK.
- PEOPLE AND PETS SHOULD BE CLEAR OF COACH WHILE OPERATING LEVELING SYSTEM.
- NEVER LIFT THE COACH COMPLETELY OFF THE GROUND. LIFTING THE COACH SO THE WHEELS ARE NOT TOUCHING GROUND WILL CREATE AN UNSTABLE AND UNSAFE CONDITION.

PRIOR TO OPERATION

The Lippert Electric Rear Stabilizer Jack shall only be operated under the following conditions:

1. The unit is parked on a reasonably level surface.
2. Be sure all person, pets and property are clear of the coach while Lippert Electric Rear Stabilizer Jack is in operation.
3. Unit must be stabilized prior to extending the slideouts to ensure unit will not move during operation of slideout system (if so equipped) and to provide the unit with a firm foundation.
4. Be sure battery is fully charged.

SYSTEM DESCRIPTION

Please read and study the operating manual before you operate the leveling system.

The Lippert Electric Rear Stabilizer Jack is a 12V DC electric motor driven system. The electric motor drives an acme threaded screw to extend and retract the stabilizer legs to stabilize the unit's rear end. The The Lippert Electric Rear Stabilizer Jack is designed to operate as a negative ground system.

There are no serviceable parts within the electric motor. If the motor fails, it must be replaced.

Disassembly of the motor voids the warranty.

Mechanical portions of the Lippert Electric Rear Stabilizer Jack are replaceable. Contact Lippert Components, Inc. to obtain replacement parts. (See page 10 for contact information).

WARNING!

YOUR COACH SHOULD BE SUPPORTED AT BOTH FRONT AND REAR AXLES WITH JACK STANDS BEFORE WORKING UNDERNEATH. FAILURE TO DO SO MAY RESULT IN PERSONAL INJURY OR DEATH.

SYSTEM MAINTENANCE

It is recommended that when operating in harsh environments (road salt, ice build up, etc.) the moving parts be kept clean and can be washed with mild soap and water. No grease or lubrication is necessary and in some situations may be detrimental to the environment and long term dependability of the system.

WARNING!

DO NOT WORK ON YOUR STABILIZER JACK UNLESS THE BATTERY IS DISCONNECTED. FAILURE TO ACT IN ACCORDANCE WITH THE FOLLOWING MAY RESULT IN SERIOUS PERSONAL INJURY OR DEATH.

ELECTRICAL SYSTEM MAINTENANCE

For optimum performance, the system requires full battery current and voltage. The battery must be maintained at full capacity. Other than good battery maintenance, check the terminals and other connections at the battery, the control switch, and the electric motor for corrosion, and loose or damaged terminals. Check motor leads under the trailer chassis. Since these connections are subject to damage from road debris, be sure they are in good condition.

NOTE - The Lippert Electric Rear Stabilizer Jack is designed to operate as a negative ground system. A negative ground system utilizes the chassis frame as a ground and an independent ground wire back to battery is necessary (see page 9 for wiring diagram). It is important that the electrical components have good wire to chassis contact. Over 90% of unit electrical problems are due to bad ground connections.

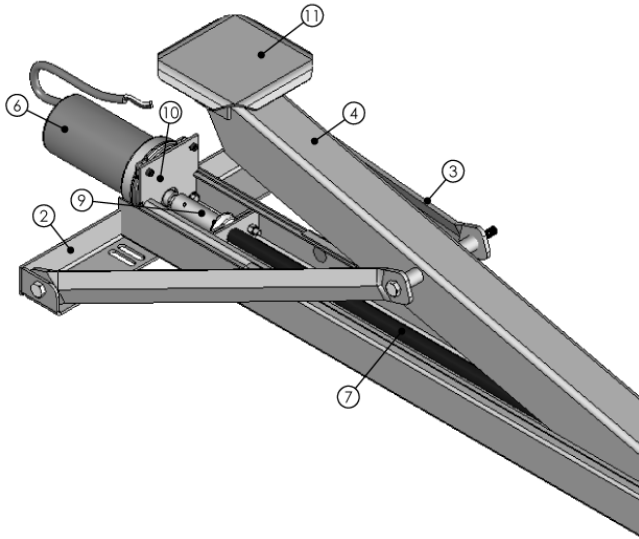

ELECTRIC REAR STABLIZER JACK

ITEM NO.	PART NUMBER	QTY
1	OUTER RAIL	1
2	MOUNTING BRACKET	2
3	JACK LEG SUPPORT ARM	4
4	JACK LEG	2
5	INNER RAIL	1
6	12VDC MOTOR	1
7	LH DRIVE ACME THREADED ROD	1
8	RH DRIVE ACME THREADED ROD	1
9	MOTOR DRIVE COUPLER	1
10	MOTOR MOUNT	1
11	FOOT PAD	2
12	THREADED ROD COUPLER	1
13	MANUAL OVERRIDE COUPLER	1

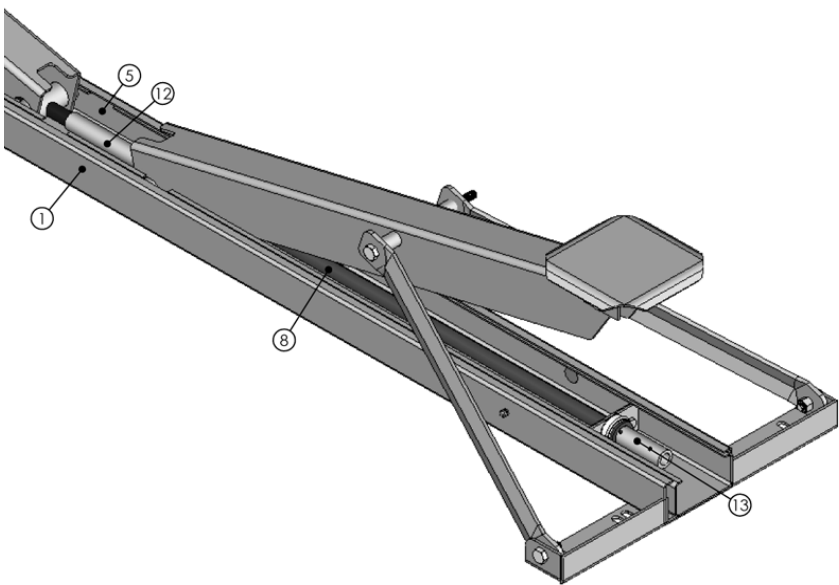

LIPPERT COMPONENTS, INC.
A Lippert Components Subsidiary

OPERATION

WARNING!

FAILURE TO ACT IN ACCORDANCE WITH THE FOLLOWING MAY RESULT IN SERIOUS PERSONAL INJURY OR DEATH.

ALWAYS MAKE SURE THAT THE LIPPERT ELECTRIC REAR STABILIZER JACK PATH IS CLEAR OF PEOPLE AND OBJECTS BEFORE AND DURING OPERATION OF THE STABILIZER JACK..

ALWAYS KEEP AWAY FROM THE STABILIZER JACK WHEN THE IT IS BEING OPERATED. THERE ARE AREAS THAT MAY PINCH OR CATCH ON LOOSE CLOTHING CAUSING PERSONAL INJURY.

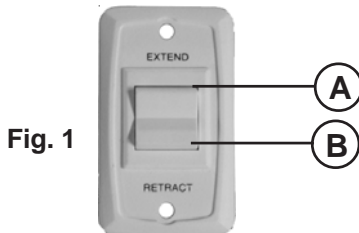

EXTENDING STABILIZER JACK

1. Level the unit.
2. Verify the battery is fully charged and hooked-up to the electrical system.
4. Press and hold the RETRACT/EXTEND switch (Fig. 1) in the EXTEND A position until the stabilizer jack foot pads contact the ground and unit is stabilized.
5. Release the switch.

RETRACTING STABILIZER JACK

1. Verify the battery is fully charged and hooked-up to the electrical system.
2. Press and hold the RETRACT/EXTEND switch (Fig. 1) in the RETRACT B position until the stabilizer jack is fully retracted.
3. Release the switch.

MANUAL OVERRIDE

WARNING!

Always disconnect battery from system prior to manually operating system. Failure to disconnect battery can cause electricity to backfeed through the motor and cause serious damage to the system as well as void the warranty.

The Lippert Electric Stabilizer Jack comes with a manual override system. Locate the manual override coupler on the end of the stabilizer jack opposite of the electric motor (Fig. 2). To manually operate the stabilizer jack, one of the wire leads from the motor must be disconnected to prevent backloading the motor and causing more damage. Next, insert the 1/2" dia. crank handle inside the coupler. The slot in the end of the crank handle (Fig. 3 C) accommodates the pin inside the coupler to allow the manual extension/retraction of the stabilizer jack. Simply rotate the crank handle clockwise to retract and counterclockwise to extend stabilizer jack.

WARNING!

The gears can be stripped out if the stab jack is manually retracted/extended to it's fullest extent and the operator continues to rotate manual override. Any damage due to misuse of the Manual Override feature will disqualify any and all claims to the Limited Warranty.

Manual Override Coupler

