



INSTALLATION & OPERATING INSTRUCTIONS

RM2351 RM2554 DM2862
RM2354 DM2652 DM3862
RM2451 DM2662 NDM1062
RM2454 DM2663 NDR1292
RM2551 DM2852

FOR YOUR SAFETY

If you smell gas:

1. Open windows.
2. Don't touch electrical switches.
3. Extinguish any open flame.
4. Immediately call your gas supplier.

POUR VOTRE SÉCURITÉ

Si vous sentez une odeur de gaz:

1. Ouvrez les fenêtres.
2. Ne touchez à aucun interrupteur.
3. Éteignez toute flamme nue.
4. Avertissez immédiatement votre fournisseur de gaz.

FOR YOUR SAFETY

Do not store or use gasoline or other flammable vapors and liquids in the vicinity of this or any other appliance.

POUR VOTRE SÉCURITÉ

Ne pas entreposer ni utiliser de l'essence ni d'autres vapeurs ou liquides inflammables à proximité de cet appareil ou de tout autre appareil.

WARNING

Improper installation, adjustment, alteration, service or maintenance can cause injury or property damage. Refer to this manual. For assistance or additional information consult a qualified installer, service agency or the gas supplier.

AVERTISSEMENT

Une installation, un réglage, une modification, une réparation ou un entretien non conforme aux normes peut entraîner des blessures ou des dommages matériels. Lisez attentivement le mode d'emploi fourni avec l'appareil. Pour obtenir de l'aide ou des renseignements supplémentaires, consultez un installateur ou un service d'entretien qualifié ou le fournisseur de gaz.



USA

Service Office
Dometic, LLC
2320 Industrial Pkwy.
Elkhart, IN 46516
Phone: 574-294-2511

Corporate Office

2320 Industrial Parkway Elkhart, IN 46515

For Service Center Assistance

Call: 800-544-4881

CANADA

Dometic, LLC
48 Zatonski, Unit 3
Brantford, ON N3T 5L8
CANADA
Phone: 519-720-9578

INTRODUCTION

Thank you for entrusting us to supply your new quality-guaranteed refrigerator. It is to be used as a recreational device designed for storage of foods, frozen foods and making ice. Please, when the refrigerator is not in use as a recreational device, turn the system off and open the door(s).

This manual describes how to install, operate and care for the following refrigerator models: RM2351, RM2354, RM2451, RM2454, RM2551, RM2554, DM2652/DM2652 (with optional fan), DM2662, DM2663, DM2852/DM2852 (with optional fan), DM2862/DM2862 (with optional fan), DM3862, NDM1062/NDM1062 (with ice maker) and NDR1292.

The installation is to be performed by qualified personnel only and must conform to all relevant local authorities. Please read this manual thoroughly before installing the refrigerator. To ensure safe and efficient operation, the refrigerator must be installed as described. Be aware of possible safety hazards when seeing alert symbols on the refrigerator as well as in this manual.

The manual should be kept and stay with the refrigerator if it is ever moved or change owners. Read it carefully to ensure that you know how to operate the refrigerator safely and correctly.

CONTENTS

INSTALLATION INSTRUCTIONS _____	3	OPERATING INSTRUCTIONS _____	12
CERTIFICATION AND CODE REQUIREMENTS	3	REFRIGERATOR OVERVIEW	12
VENTILATION REQUIREMENTS	3	INSTRUCTIONS FOR USE	15
INSTALLATION PROCEDURE	6	STORAGE COMPARTMENTS	17
DOOR MOUNTING INSTRUCTIONS	10	PRODUCT CARE	19
REFRIGERATOR REMOVAL	11	MAINTENANCE & SERVICE	21
		TROUBLESHOOTING	23
		APPENDIX A - SPARE PARTS	24
		APPENDIX B - CONSUMER SUPPORT	26
		APPENDIX C - DOMETIC WARRANTY & MAINTENANCE SCHEDULE	27
		APPENDIX D - REARVIEW EQUIPMENT	30
		APPENDIX E - WIRING DIAGRAMS	33

SYMBOLS

The following symbols are used throughout the manual:



Indicates a potentially hazardous situation, which, if not avoided, could result in death or serious injury.



Indicates a potentially hazardous situation, which, if not avoided, may result in minor or moderate injury.



Used without the safety alert symbol indicates, a potentially hazardous situation which, if not avoided may result in property damage.



Information



Step-by-step instructions

INSTALLATION INSTRUCTIONS

CERTIFICATION AND CODE REQUIREMENTS

This appliance is certified under the latest edition of ANSI Z21.19•CSA 1.4 Refrigerators using gas fuel. The installation must conform with local codes, or in absence of local codes, the following standards as applicable.

In the U.S. the installation must conform with:

- National Fuel Gas Code, ANSI Z223.1/NFPA 54 (latest edition).
- Recreational Vehicles Code, ANSI A119.2 (latest edition).
- Manufactured Home Construction and Safety Standard, Title 24 CFR, Part 3280.

If an external electrical source is utilized, the refrigerator, when installed, must be electrically grounded in accordance with local codes or, in the absence of local codes, the National Electrical Code, ANSI/NFPA 70 - (latest edition).

In CANADA, the installation must conform with:

- Natural Gas and Propane Installation Code, CSA B149.1
- CSA Z240 RV Series, Recreational Vehicles.
- Current CSA Z240.4, Gas-equipped Recreational Vehicles and Mobile Housing.

If an external electrical source is utilized, the refrigerator, when installed, must be electrically grounded in accordance with local codes or, in the absence of local codes, the Canadian Electrical Code, CSA C22.1, Parts I and II - (latest edition).



VENTILATION REQUIREMENTS

GENERAL INFORMATION

Ventilation is one of the requirements for proper cooling unit operation. The installation should be made in such a manner as to separate the combustion system from the living space of the mobile home or recreational vehicle. Openings for air supply or for venting of combustion products should have a minimum dimension of not less than 1/4 inch.

Proper installation requires one lower fresh air intake and one upper exhaust vent. Certified installations require one roof vent and one lower side vent. The ventilation kits shown in this manual have been certified for use with the different models as displayed in the “Certified Vent System Kits” table.

The ventilation kits must be installed and used without modification! An opening toward the outside at floor level in the refrigerator compartment has to be provided for ventilation of heavier-than-air fuel gases. The lower vent of the recommended kits is provided with proper size openings. The flow of combustion and ventilating air must not be obstructed.

CAUTION

It is of especially importance that the airflow around the burner housing, the boiler insulation and the flow of combustion gases must not be obstructed. Items placed in the vicinity of the refrigerator compartment accordingly must be secured away from the refrigerator tubing and flue.

The lower side vent is fitted with a panel, which provides an adequate access opening for ready serviceability of the burner and control manifold of the refrigerator. This should be centered on the back of the refrigerator.

Certified Vent System Kits			
Model	Kit No.	Components	Part no.
RM2351 RM2354	2A	Roof Base Roof Cover Lower Side Vent Lower Side Vent	3103633.XXX* or 3310893.XXX* 3103634.XXX* or 3310894.XXX* 3109350.XXX* RM183
	3A	Upper Side Vent Lower Side Vent Power Vent Ass'y Upper Side Vent Upper Side Vent Lower Side Vent Lower Side Vent	RM123A RM183 3108705.751** RM123A 3109492.003 RM183 3109492.003
RM2451 RM2454 RM2551 RM2554	3A	Roof Base Roof Cover Lower Side Vent	3103633.XXX* or 3310893.XXX* 3103634.XXX* or 3310894.XXX* 3109350.XXX*
DM2652 DM2662 DM2663 DM2852 DM2862 DM3862 NDM1062	4A	Roof Base Roof Cover Lower Side Vent	3103633.XXX* or 3310893.XXX* 3103634.XXX* or 3310894.XXX* 3109350.XXX*
NDR1292	5A	Roof Base Roof Cover Lower Side Vent Power Vent Ass'y	3103633.XXX* or 3310893.XXX* 3103634.XXX* or 3310894.XXX* 3103649.XXX* 3108705.744**

* Replace “XXX” with the color code numbers. For color codes, contact your supplier.

** Alternate instructions forwarded with the Ventilator Kit.

For further information, contact your dealer or distributor.

VENTILATION REQUIREMENTS

VENTILATION HEIGHTS

It is essential that all maximum or minimum dimensions are strictly maintained, as the performance of the refrigerator is dependent on adequate flow of air over the rear of the refrigerator.

Minimum ventilation heights				
	Roof vent and lower side vent (A)		Upper and lower side vent (B)	
	inches	mm	inches	mm
RM2351 RM2354	31	787	34	864
RM2451 RM2454	37-3/4	960		
RM2551 RM2554	44-1/2	1130		
DM2652 DM2662 DM2663	57-3/4	1465		
DM2852 DM2862 DM3862 NDM1062	63-3/4	1620		
NDR1292	65	1651		

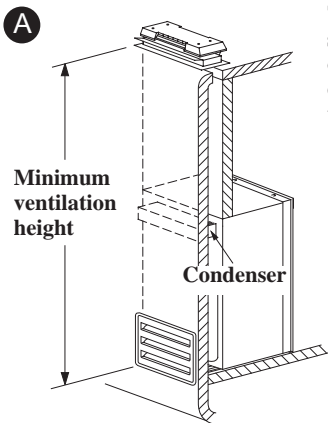

The upper vent should be centered over the condenser coil at the back of the refrigerator.

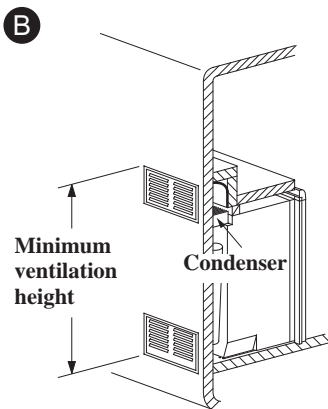

CLEARANCES

Minimum clearances (in inches) to combustible materials:

Top (G)	0
Side (K)	0
Bottom (L)	0
Rear (M ¹)	0 / 1 (RM2351 & RM2354)

¹ The distance between the rearmost part of the refrigerator and the wall behind it.

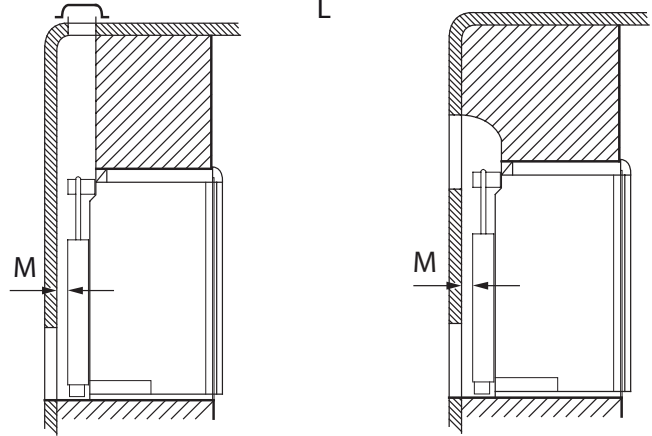
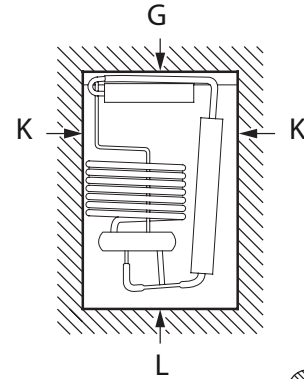

SIDE VIEW WITH DUCT SYSTEM

DM2852, DM2862, DM3862 & NDM1062

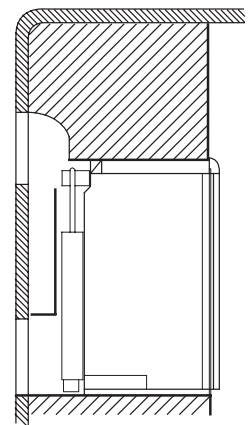
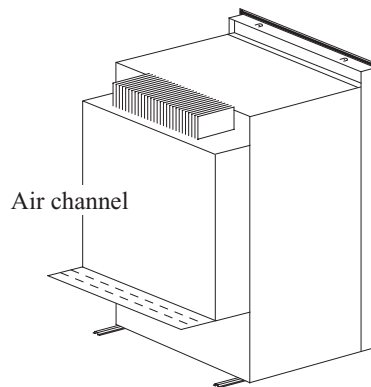

For installation instructions of the Air Channel, please refer to "INSTALLATION OF AIR CHANNEL", Rev. 825129100 or later.

VENTILATION REQUIREMENTS

OVERALL AND RECESS DIMENSIONS

Model		Overall			Recess		
		Height A	Width B	Depth C	Height H	Width W	Depth D
RM2351 RM2354	inches	30-5/32	21-7/8	22-22/32	29-3/4	20-1/2	21-3/8
	mm	766	556	577	756	521	542
RM2451 RM2454	inches	37-3/8	24-7/8	24-11/16	39-9/16	23-11/16	24
	mm	948	632	627	928	602	610
RM2551 RM2554	inches	43-1/2	24-7/8	24-11/16	42-5/8	23-11/16	24
	mm	1104	632	627	1083	602	610
DM2652 DM2662 DM2663	inches	54-21/32	24-7/8	26-1/32	53-3/4	23-11/16	24
	mm	1388	632	661	1365	602	610
DM2852 DM2862 DM3862	inches	60-51/64	24-7/8	26-1/32	59-15/16	23-11/16	24
	mm	1544	632	661	1522	602	610
NDM1062	inches	60-54/64	24-7/8	26-5/8	59-15/16	23-11/16	24*
	mm	1544	632	676	1522	602	610*
NDR1292	inches	59-31/32	33-11/16	26-21/32	59-1/16	32-3/4	24*
	mm	1523	855	677	1500	832	610*

* Add 1" (25 mm) depth for units with one or two optional ventilator fans.

Side view

View from above

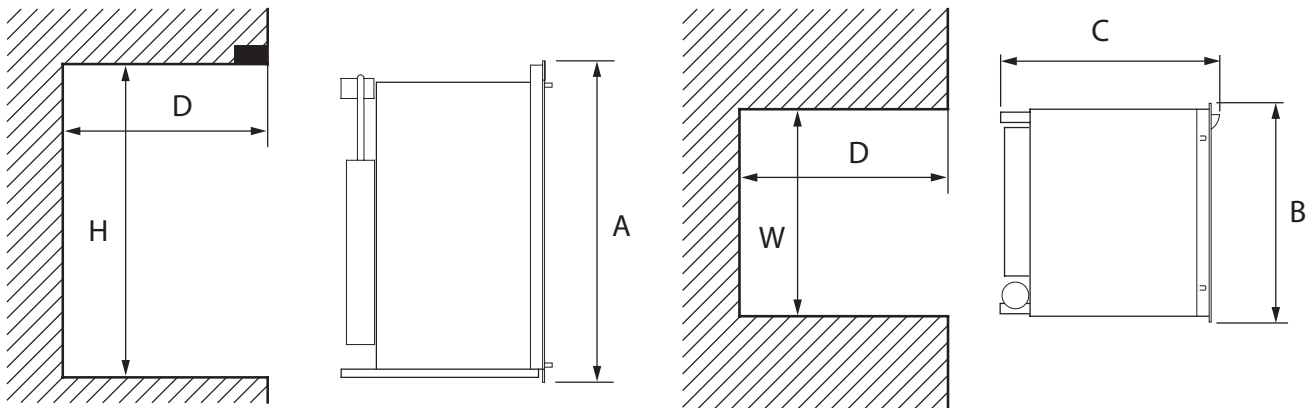

General view. Features may vary according to model.

INSTALLATION PROCEDURE

INSTALLING THE REFRIGERATOR



Be careful when installing the refrigerator models **NDM1062 & NDR1292**. These are equipped with the latest vacuum insulated panel technology. The insulating panels are located on the top, back, bottom, sides and doors. If the surface is punctured, loss of insulation will occur, resulting in poor refrigerator performance.

For a proper installation, follow these instructions:

- Make sure the floor is solid and level.
- The refrigerator must be level and installed in a substantial enclosure.
- Do not install the appliance directly on carpeting. Carpeting must be removed or protected by a metal or wood panel beneath the appliance, which extends at least full width and depth of the appliance.
- **RM2451, RM2454, RM2551, RM2554, DM2652, DM2662, DM2663, DM2852, DM2862, DM3862, NDM1062 & NDR1292**

A **wood strip** must be in place across the upper opening of the enclosure. The top frame of the refrigerator will be anchored to the wood strip with screws.

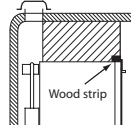

- When installing the refrigerator in the enclosure, all areas within the recess have to be sealed. Verify that there is a complete seal between the front frame of the refrigerator and the top, sides and bottom of the enclosure. A length of sealing strip is applied to the rear surface of the front frame for this purpose. The sealing strip should provide a complete isolation of the appliance's combustion system from the vehicle interior.

RM2351 and RM2354: Apply a sealing strip to the foremost floor of the enclosure.

Be careful not to damage the sealing strip when the refrigerator is put in place!

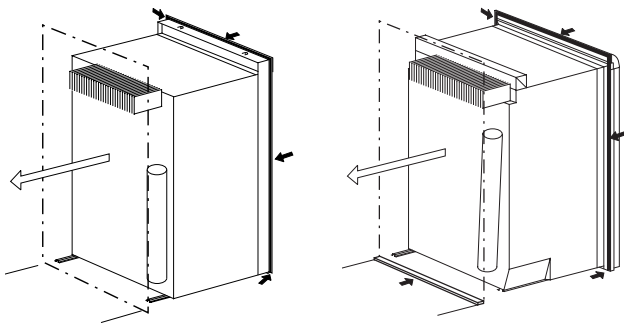

RM2451, RM2454, RM2551, RM2554, DM2652, DM2662, DM2663, DM2852, DM2862, DM3862, NDM1062 & NDR1292

RM2351 & RM2354

SECURING THE REFRIGERATOR

It is important to follow the sequence in securing refrigerator in enclosure since failure in doing so can cause leakage between the frame and cabinet. Any space between the counter, storage area or ceiling and top of the refrigerator greater than 1 1/2 inches should be blocked. The heat produced at the rear of the refrigerator will become trapped in this space, making the top of the refrigerator hot and reduce the efficiency of the refrigerator.

After the refrigerator is put in place (ensuring a combustion seal at the front frame), the refrigerator is to be secured in the enclosure with screws (not included).

RM2351 & RM2354

Install the five screws in the following order:

1. Four screws installed through the front frame. (To cover the screw heads, use the plugs in the parts bag.)
2. One screw installed in the rear base.

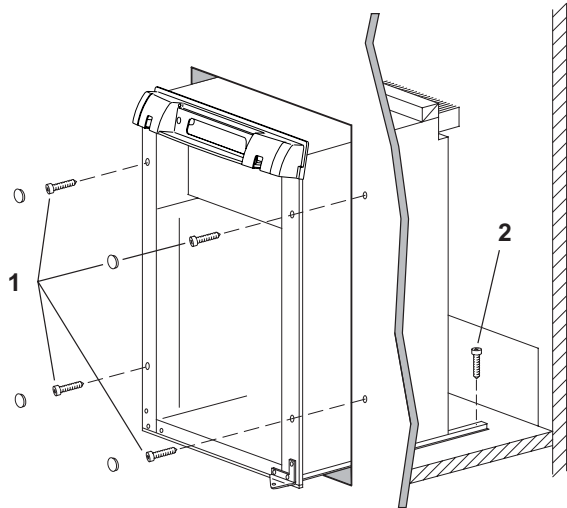

INSTALLATION PROCEDURE

RM2451, RM2454, RM2551, RM2554, DM2652, DM2662, DM2663, DM2852, DM2862, DM3862 & NDM1062

Install the screws in the following order:

 1. **Two screws installed through the front base. (Installation of the lower front strip.)**

The refrigerator is provided with a lower front strip (shipped as a loose part). Attach the front strip after the refrigerator is set into the cutout opening.

- a) Install the lower front strip by sliding it under the bottom hinge plate. The hinge plate can be on the right or left side depending on the door swing. Once the lower front strip is slipped under the hinge, the part is possible to swing into place.

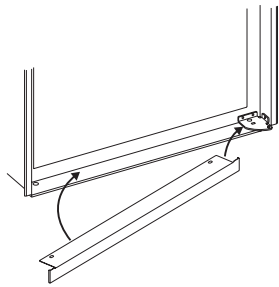

- b) Secure the refrigerator and the lower front strip with two screws: One screw through the hinge and on the opposite side and then, one screw through the lower front strip.

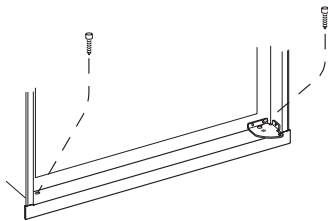

2. **Two screws installed in the top frame.**

- a) Open the door. Gently push the tabs out of the hole in the hinge with a flat blade screwdriver (both sides).
- b) Carefully tilt the top decoration panel and lift to remove from top frame. Be careful not to damage the circuit board and wires.
- c) Install the two screws in the top frame, the holes are accessible from underneath.
- d) Seal the opening for the screws with aluminum tape.
- e) Replace the top decoration panel. Be careful not to pinch the wires behind the panel. Make sure the tabs snap back into the holes in the hinge plate.

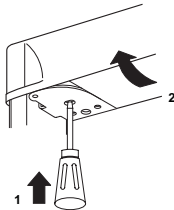

3. **One screw installed in the rear base.**

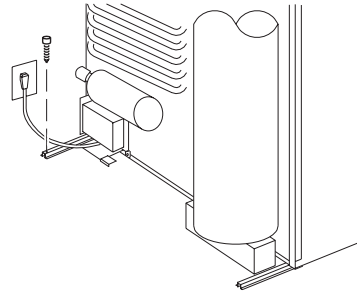

NDR1292

Install the screws in the following order:

 1. **Two screws installed through the front base. (Installation of the lower front strip.)**

The refrigerator is provided with a lower front strip (shipped as a loose part). Attach the front strip after the refrigerator is set into the cutout opening.

- a) Install the lower front strip by sliding it under the bottom hinge plate.

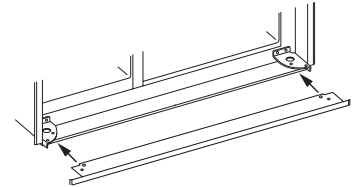

- b) Secure the refrigerator and the lower front strip with two screws: One screw through each hinge.

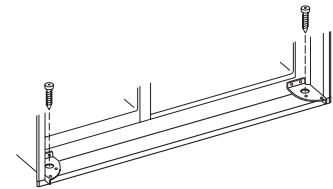

2. **Screws installed in the top frame.**

- a) Open the doors and remove the four screws that secure the top decoration panel to the top frame. Two screws are accessible from underneath and two are located on each side of the lock retainer securing the decoration panel to the front frame. Save screws for reinstallation of the top decoration panel.
- b) See step 2, b-e in the previous instruction.

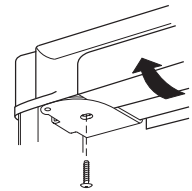

3. **Two screws installed in the rear base.**

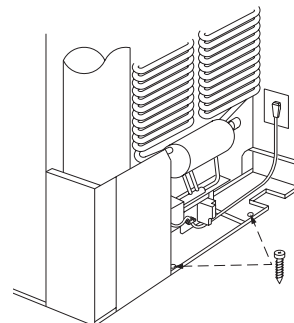

INSTALLATION PROCEDURE

DRAIN WATER HOSE

Drill a hole through flooring. To avoid damage to the hose, the hole must be positioned so that the hose doesn't touch the boiler casing. Seal around the hose that goes through the drilled hole and ensure that it does not kink when run through the floor. Check to make sure that the supplied hose is long enough in order for the water to drain outside of the vehicle. If not, the installer will have to supply the extra length of hose.

RM2351 & RM2354

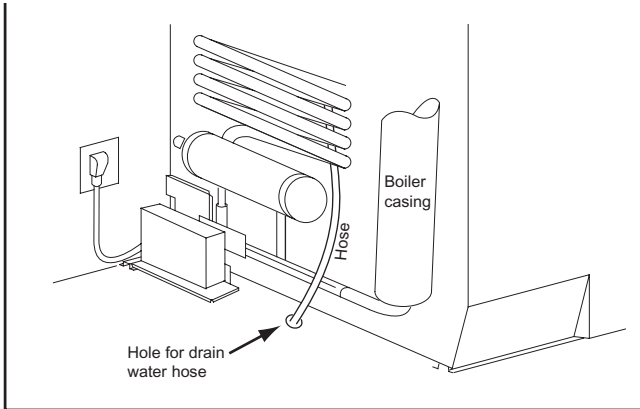

RM2451, RM2454, RM2551, RM2554, DM2652, DM2662, DM2663, DM2852, DM2862, DM3862 & NDM1062

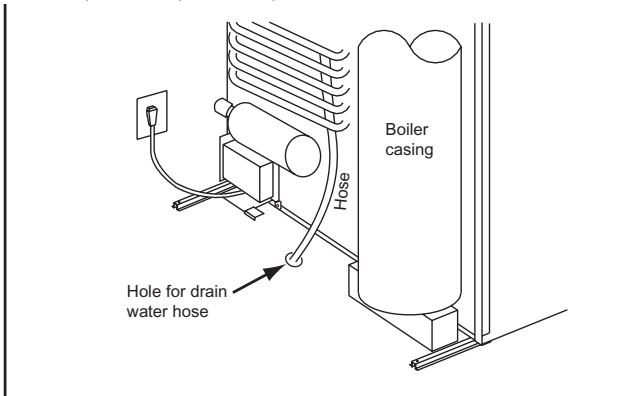

NDR1292

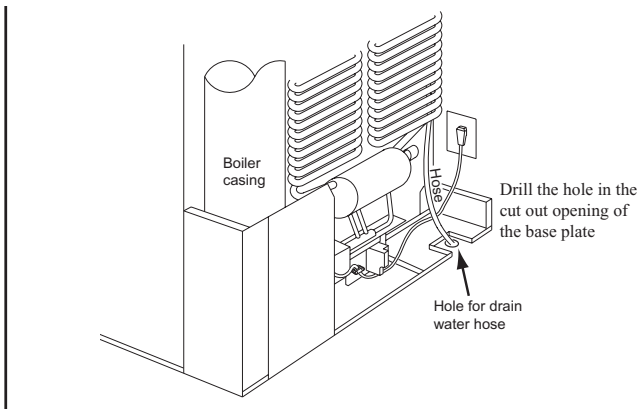

CONNECTIONS

Gas connection

Hook up to the gas supply line is accomplished at the manual gas valve, which is furnished with a 3/8" SAE (UNF 5/8" -18) male flare connection. All completed connections should be examined for leaks using a solution of liquid detergent and water.

⚠ WARNING

EXPLOSION HAZARD. Never use an open flame to check for gas leaks. Failure to heed this warning could cause an explosion resulting in death or severe personal injury.

The gas supply system must incorporate a pressure regulator to maintain a supply pressure of not more than 11 inches water column. When testing the gas supply system at test pressures:

- **> 1/2 psi** - the refrigerator and its individual shutoff valve must be disconnected from the gas supply piping system.
- **≤ 1/2 psi** - the appliance must be isolated from the gas supply piping system by closing its individual manual shutoff valve.

If detailed instructions on the installation and connection to the gas supply are required, please contact your dealer or distributor.

Testing LP gas safety shut off

The gas safety shut off must be tested after the refrigerator is connected to LP gas supply.

RM2354, RM2454, RM2554, DM2662, DM2663, DM2862, DM3862, NDM1062 & NDR1292

To test the gas safety shut off, follow these steps:

1. Start the refrigerator. Switch to GAS mode.
2. Check that the gas flame is lit and the GAS mode indicator lamp is on.
3. Close the manual gas shutoff valve at the back of the refrigerator.
4. Wait for approx. 6 minutes. The CHECK indicator lamp should be lit and the GAS mode indicator lamp should be off.
5. Remove the protection cover.
6. Open the manual gas shutoff valve. Do not change any button positions on the control panel.
7. Apply a non corrosive commercial bubble solution to the burner jet orifice. No bubbles should appear at the opening of the burner jet orifice. The presence of bubbles indicates a defective gas safety shutoff, and service is required.
8. If no bubbles are present at the burner jet orifice, rinse it with fresh water. Be careful not to damage the burner jet orifice.

INSTALLATION PROCEDURE

9. Put back the cover.
10. Press the ON/OFF button off and then back on. Normal operation of the burner should return.
11. Allow the burner to operate for a minimum of five minutes.

RM2351, RM2451, RM2551, DM2652 & DM2852

To test the gas safety shut off, follow these steps:

-  1. Start the refrigerator without connecting to 120V AC.
2. Check that the gas flame is lit. In AUTO mode, the AUTO mode indicator lamp is on.
3. Follow steps 3-11 in the previous instruction.

Electrical connection

120 V AC connection

The refrigerator is equipped with a grounded three-prong plug for protection against shock hazards. It should be plugged directly into a properly grounded three-prong receptacle. **Do not cut or remove the grounding prong from this plug!**

The free length of the cord is 2 feet. It should be routed to avoid direct contact with the burner cover, flue cover or any other components that could damage the cord insulation.

To allow easy access through the vent door, it is recommended that the receptacle is placed like this:

- **RM2351 & RM2354**
To the left of the refrigerator and **4-6"** above the refrigerator mounting floor
- **RM2451, RM2454, RM2551, RM2554, DM2652 & DM2852**
To the left of the refrigerator and **6"** above the refrigerator mounting floor
- **DM2662, DM2663, DM2862, DM3862 & NDM1062**
To the left of the refrigerator and **3"** above the refrigerator mounting floor.
- **NDR1292**
To the right of the refrigerator and **10"** above the refrigerator mounting floor.

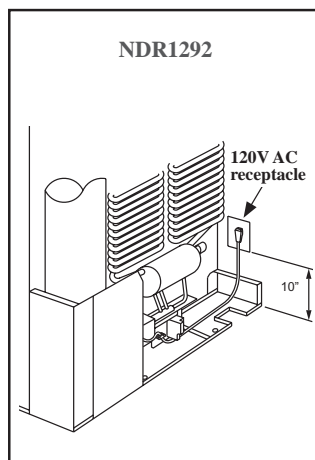
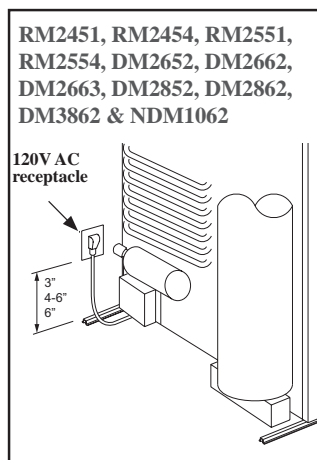

12V DC connection

RM2451, RM2551, DM2652 & DM2852: These refrigerator models are not designed for 12V DC operation of the cooling system. However, 12V DC must be supplied to operate the controls.

RM2354, RM2454, RM2554, DM2662, DM2663, DM2862, DM3862 & NDM1062: These refrigerator models require a continuous 12V DC supply to maintain the automatic energy system.

The connection is made to the positive (+) and negative (-) terminals of the terminal block on back of the refrigerator.

Correct polarity must be observed when connecting to the DC supply. Do not use the chassis or vehicle frame as one of the conductors. Connect two wires at the refrigerator and route to the DC supply. Ensure the connections are clean, tight and free from corrosion.

Ensure that the wires from the battery to the refrigerator are able to handle the load. The distance the current must travel from the battery to the refrigerator dictates the AWG wire size to be used. Inadequate wire sizes can result in a voltage drop which affects the refrigerator performance.

For 3-way models, the voltage drop affects the wattage output of the 12V cartridge heater and the refrigerator performance. The 12V DC heater is fused with a 30 amp. in-line blade fuse.

Recommended wire sizes are displayed in the following table:

MAXIMUM TOTAL CONDUCTOR WIRE LENGTH			
MODEL \ WIRE	Size	Length	
	AWG	ft	m
RM2351	14	17	5
RM2451	12	27	8
RM2551			
DM2652			
DM2662			
DM2852			
DM2862			
DM3862			
NDM1062			
NDR1292			
RM2354	10	17	5
RM2454	8	27	8
RM2554			
DM2663			

DOOR MOUNTING INSTRUCTIONS

REVERSING THE DOOR SWING

For all models, except **NDR1292**, the refrigerators are equipped with hinges that makes it possible to change the direction the door opens by moving the hinges to the opposite side. A special hinge kit must be used in order to change the door swing. For conversion kit number, see APPENDIX A - SPARE PARTS. For additional information, please contact service point or distributor service dept. for assistance.

MOUNTING THE DOOR PANEL(S)



Optional door insert panels are available for all models except **NDR1292**. The refrigerator is normally delivered without door panel(s).

Before starting the mounting work, read this instruction thoroughly and check that the panel dimensions are in compliance with those given in the following table:

PANEL DIMENSIONS max. thickness 5/32" (4 mm)					
		Height		Width	
		max	min	max	min
UPPER					
	mm	403	401	527	524
	inch	15-27/32	15-25/32	20-3/4	20-5/8
LOWER /SINGLE DOOR					
RM2351 RM2354	mm	667	665	498	496
	inch	26-17/64	26-3/16	19-5/8	19-17/32
RM2451 RM2454 DM2652 DM2662 DM2663	mm	827	825	527	524
	inch	32-9/16	32-1/2	20-3/4	20-5/8
RM2551 RM2554 DM2852 DM2862 NDM1062	mm	983	981	527	524
	inch	38-11/16	38-5/8	20-3/4	20-5/8
FROZEN FOOD COMPARTMENT					
NDR1292	mm	1402	1400	288	265
	inch	55-3/16	55-1/8	10-9/16	10-7/16
FRESH FOOD COMPARTMENT					
NDR1292	mm	1402	1400	430	427
	inch	55-3/16	55-1/8	16-15/16	16-13/16

With screws

To mount the panel, follow these steps:



1. Open the door 90 degrees.
2. On new refrigerators, the decoration strip is taped inside the door; if installed on the door, remove the door decoration strip (2) by removing its three screws (1).
NDR1292:
Fresh food compartment door - remove three screws.
Freezer compartment door - remove two screws.
3. Insert the vertical edges into the grooves of the door frame (3).
4. Push the panel downwards so that the lower horizontal edge of the panel (4) is fitted into the bottom groove (5).
5. Put the decoration strip across the door so that the gap is covered. Secure the decoration strip with the screws removed in step 2.

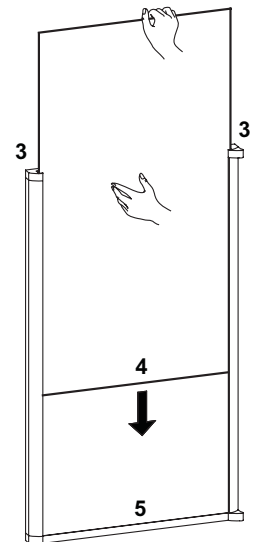
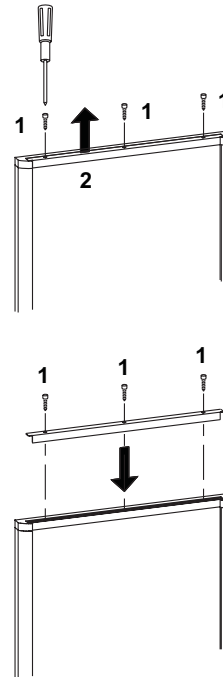

DOOR MOUNTING INSTRUCTIONS

Snap in

To mount the panel, follow these steps:

1. Open the door 90 degrees.
2. On new refrigerators, the decoration strip are taped inside the door; if installed on the door, remove the door decoration strip (2) by gently pushing the four tabs away with a flat blade screwdriver (1).
3. Insert the vertical edges into the grooves of the door frame (3).
4. Push the panel downwards so that the lower horizontal edge of the panel (4) is fitted into the bottom groove (5).
5. Snap in the decoration strip (2).

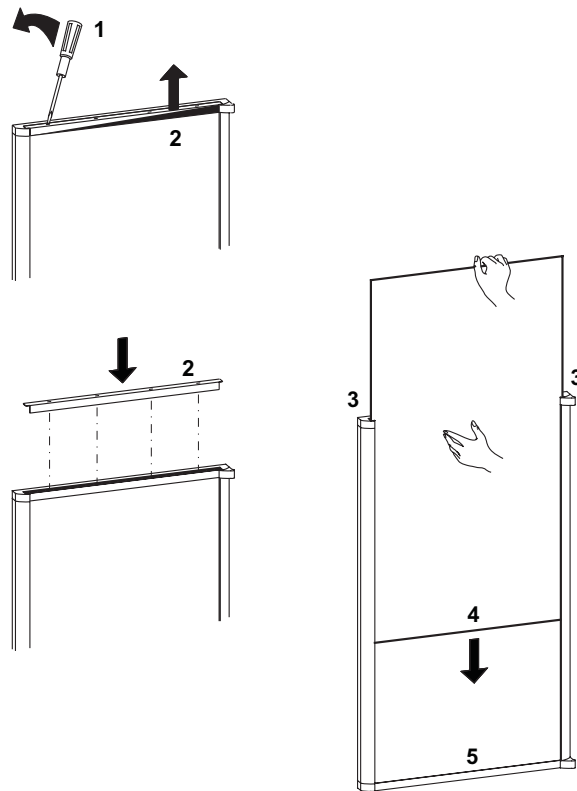

REFRIGERATOR REMOVAL

Before removing the refrigerator:

- Verify that the AC and DC voltage leads are disconnected.
- Shut off the gas supply.
- Disconnect the gas supply line at the rear of the refrigerator. Always use a back up wrench when loosening and tightening connections.

To remove the refrigerator, follow these steps:

1. Cap the gas supply line.
2. Loosen the screws anchoring the refrigerator to the enclosure.
3. Slide the refrigerator out of the compartment.

Replacement is the reverse of removal. When reinstalling the refrigerator, make sure the sealing strips are properly positioned. Check all connections for gas leaks.

OPERATING INSTRUCTIONS

REFRIGERATOR OVERVIEW

ABSORPTION COOLING SYSTEM

In an absorption refrigerator system, ammonia is liquefied in the finned condenser coil at the top rear of the refrigerator. The liquid ammonia then flows into the evaporator (inside the freezer section) and is exposed to a circulating flow of hydrogen gas, which causes the ammonia to evaporate, creating a cold condition in the freezer.



When starting this refrigerator for the very first time, the cooling cycle may require up to four hours of running time before the cooling unit is fully operational.

The tubing in the evaporator section is specifically sloped to provide a continuous movement of liquid ammonia, flowing downward by gravity through this section.

Sodium chromate is used for corrosion protection (less than 2 weight % of the coolant).

Leveling the refrigerator

Leveling is one of the requirements for proper operation with absorption refrigerators. To ensure proper leveling the vehicle needs to be leveled only so it is comfortable to live in (no noticeable sloping of floor or walls).

Any time the vehicle is parked for several hours with the refrigerator operating, the vehicle should be leveled to prevent this loss of cooling.

If the refrigerator is operated when it is not level and the vehicle is not moving, liquid ammonia will accumulate in sections of the evaporator tubing. This will slow the circulation of hydrogen and ammonia gas, or in severe cases, completely block it, resulting in a loss of cooling.

When the vehicle is moving, the leveling is not critical, as the rolling and pitching movement of the vehicle will pass to either side of level, keeping the liquid ammonia from accumulating in the evaporator tubing.

AUTOMATIC ENERGY SELECTOR SYSTEM

The refrigerator is equipped with an automatic energy selector system. The user turns the refrigerator on and then, the refrigerator automatically selects the most suitable energy source available, either 120 V AC or LP gas operation. The system can be set by the user to be fully automatic (AUTO mode is selected) or to operate on LP gas only (AUTO mode is off).

On 3-way models, the control system can manually be set to DC mode (DC operation). The DC mode overrides all other operating modes.

The refrigerator controls will work down to 9.6 V DC.

MODES OF OPERATION

AUTO mode - AES/AUTO mode

When operating in AUTO - AES/AUTO mode, the AUTO - AES/AUTO mode indicator lamp is illuminated. The control system will automatically select between AC and GAS operation. AC has priority over GAS. Should AC become unavailable, the system automatically switches to GAS. As soon as AC becomes available again, the control will switch back to AC regardless of the status of the GAS operation.

If the CHECK indicator lamp is illuminated the controls have failed to ignite the burner in the GAS mode. To restart an ignition attempt with the CHECK lamp illuminated (or to turn off the CHECK lamp), press the ON/OFF button OFF and back ON again. The control system activates the ignition system and makes three attempts to light the burner for a period of approx. 45 sec. at two minutes interval. Should 120 V AC become available while the CHECK indicator lamp is on, the CHECK lamp will *not* turn off until the ON/OFF button is pressed OFF and then ON again.

GAS mode

RM2351, RM2451, RM2551, DM2652 & DM2852:

When operating in GAS mode, the AUTO mode indicator lamp will be off.

RM2354, RM2454, RM2554, DM2662, DM2663, DM2862, DM3862, NDM1062 & NDR1292: When operating in GAS mode, the GAS mode indicator lamp is illuminated.

This mode provides LP gas only. The control system activates the ignition system and attempts to light the burner for a period of approx. 45 sec. at two minutes interval. If unsuccessful, the CHECK indicator lamp will illuminate.

To restart GAS operation, press the ON/OFF button to OFF and then back ON. The control system attempts a new ignition sequence.

Purging air from the lines

If the refrigerator has not been used for a long time - or - the LP tanks have just been refilled, air may be trapped in the supply lines. To purge the air from the lines, turn the refrigerator off and on by pressing the ON/OFF button. If the flame is not lit within 45 seconds, turn the refrigerator off and back on again. This procedure can be repeated 3 to 4 times. If repeated attempts fail to start the LP gas operation, check to make sure that the LP gas supply tanks are not empty and that all manual shutoff valves in the lines are open.

WARNING

FIRE OR EXPLOSION HAZARD. When refueling or parked near gasoline pumps, shut off all LP gas appliances. Failure to heed this warning could cause a fire or explosion resulting in death or severe personal injury.

REFRIGERATOR OVERVIEW

DC mode

RM2354, RM2454, RM2554 & DM2663

When operating in DC mode (3-way models only), the DC mode indicator lamp is illuminated and all other lamps are off. To select another operating mode, turn off the DC mode by pressing the DC selector button. The DC lamp is turned off.

When there is no charging of the house battery, switch to AUTO mode or GAS mode since running the refrigerator on 12 V DC will quickly drain the battery.

LIMP MODE OF OPERATION

In the event of a failure of a major operating component, the control system will continue to operate the cooling system.

RM2351, RM2451, RM2551, DM2652 & DM2852

If the control can not read the temperature sensor and control the preset temperature, the control will run the cooling unit continuously at the energy source available. The refrigerator will continue to operate in this mode indefinitely - or - until a new sensor is installed and the system reset.

RM2354, RM2454, RM2554, DM2662, DM2663, DM2862, DM3862, NDM1062 & NDR1292

Two modes of operation can occur:

- 1) The first limp mode of operation will execute if the display module becomes non functional. The control system reverts to full automatic operation selecting the best energy source available with AC, DC (3-way only) and GAS priority. The temperature setting is maintained at the mid position. The power module will continually attempt to reestablish operation of the display module.
- 2) The second limp mode of operation will execute when a failure of the temperature sensing device or associated electronic circuitry occurs. If this should happen, the control system operates on the energy source selected via the control panel. The cooling unit runs continuously on the selected energy source. The refrigerator continues to operate in this mode indefinitely or until a new sensor is installed and the system is reset.

CLIMATE CONTROL SYSTEM

DM2652, DM2662, DM2663, DM2852, DM2862, DM3862, NDM1062 & NDR1292

During the summer months of high temperatures and humidity, the metal frame between the freezer and fresh food compartments may have water droplets forming. The number of water droplets will increase if the vehicle is not air conditioned during these months. The refrigerator comes standard with a 12 V DC climate control that will evaporate the water droplets when they form. The climate control can be left on continuously or used only when temperatures require it. Note that when turned on, the climate control will draw 12 V DC power continuously. Turn it off when a charging source is not available.

LOW AMBIENT CONTROL

DM3862, NDM1062 & NDR1292

The refrigerator is equipped with an exclusive feature that allows for trouble-free operation in low ambient temperature (like below 50°F) for extended periods of time. Once the outdoor temperature is above 50°F, the low ambient switch should be turned off.

THERMOSTAT

RM2354, DM2662, DM2663, DM2862, DM3862, NDM1062 & NDR1292

The thermostat controls both the gas and electric operation, thereby eliminating the necessity of resetting each time a different energy source is employed. After the initial start-up, the thermostat should be adjusted to the desired temperature setting.

CONTROL PANEL

RM2351, RM2451, RM2551, DM2652 & DM2852

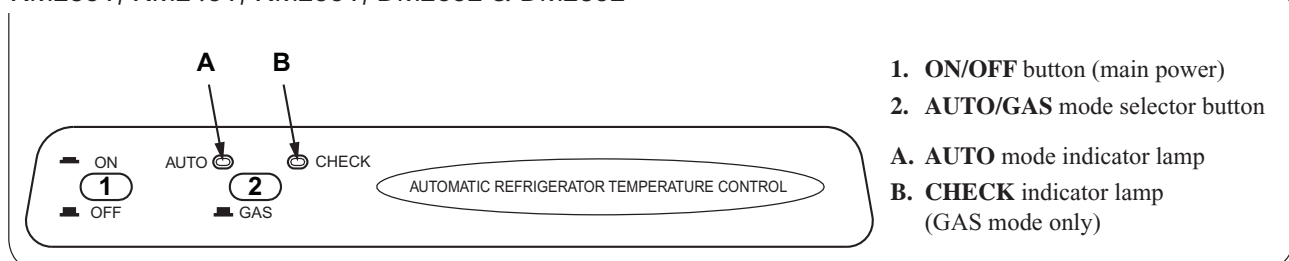

REFRIGERATOR OVERVIEW

RM2354, RM2454, RM2554 & DM2663

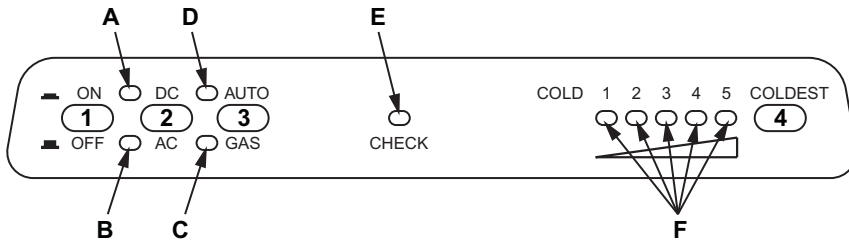

1. ON/OFF button (main power)
 2. DC mode selector button
 3. AUTO/GAS mode selector button
 4. Temperature selector button
- A. DC mode indicator lamp
 B. AC mode indicator lamp
 C. GAS mode indicator lamp
 D. AUTO mode indicator lamp
 E. CHECK indicator lamp (GAS mode only)
 F. Temperature indicator lamps

DM2662, DM2862 & NDM1062

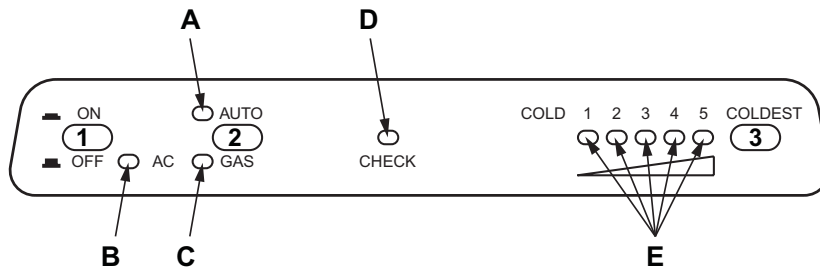

1. ON/OFF button (main power)
 2. AUTO/GAS mode selector button
 3. Temperature selector button
- A. AUTO mode indicator lamp
 B. AC mode indicator lamp
 C. GAS mode indicator lamp
 D. CHECK indicator lamp
 E. Temperature indicator lamps

DM3862, NDM1062 & NDR1292

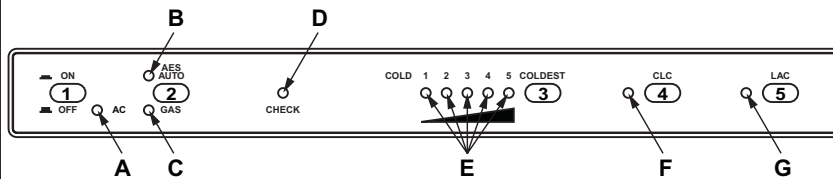

1. ON/OFF button (main power)
 2. AES/AUTO/GAS mode selector button
 3. Temperature selector button
 4. Climate control button
 5. Low ambient control button
- A. AC mode indicator lamp
 B. AES/AUTO mode indicator lamp
 C. GAS mode indicator lamp
 D. CHECK indicator lamp
 E. Temperature indicator lamps
 F. Climate control indicator lamp
 G. Low ambient control indicator lamp

NDR1292

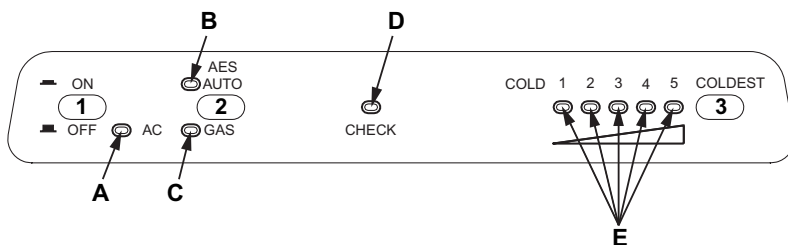

1. ON/OFF button (main power)
 2. AES/AUTO/GAS mode selector button
 3. Temperature selector button
- A. AC mode indicator lamp
 B. AES/GAS mode indicator lamp
 C. GAS mode indicator lamp
 D. CHECK indicator lamp
 E. Temperature indicator lamps

INSTRUCTIONS FOR USE

STARTUP

⚠ WARNING

FIRE HAZARD. Before lighting the gas burner, after that the RV has not been used for some time, please check that the gas path between the burner jet and the burner tube has not been obstructed. Failure to heed this warning could cause a fire resulting in personal injury.

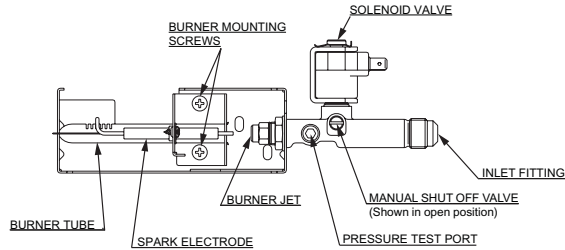

Before starting the refrigerator:

- Check that all the manual gas valves are in the ON position.
- Make sure that a continuous 12V DC supply is available for the electronic control to function.

TURNING ON/OFF

To turn on:

1. Press the ON/OFF button.
2. Select operation mode:
 - **AUTO - AES/AUTO mode** (AC and GAS)
Press the AUTO/GAS - AES/AUTO/GAS mode selector button (if not already on). The illuminated lamp indicates the selected mode.
(If the CHECK indicator lamp is illuminated, see REFRIGERATOR OVERVIEW > MODES OF OPERATION > AUTO MODE - AES/AUTO MODE for further information.)
 - **GAS mode** (GAS operation only)
Press the AUTO/GAS - AES/AUTO/GAS mode selector button to turn off the AUTO mode (if not already off).
(Within 45 seconds the burner should be ignited and operating normally. If not, see REFRIGERATOR OVERVIEW > MODES OF OPERATION > GAS MODE for further information.)
 - **DC mode** (3-way models only)
Press the DC mode indicator button. The DC lamp will be turned on. To select AUTO or GAS mode, turn off the DC mode by pressing the DC mode selector button. The DC lamp will then be turned off.
3. If necessary, adjust the thermostat by pressing the Temperature selector button.
(RM2351, RM2451, RM2551, DM2652 & DM2852: The temperature is controlled by a factory preset temperature setting.)

To turn off

The refrigerator may be shut off while in any mode of operation by pressing the main power ON/OFF button to the OFF position. This shuts off all DC power to the refrigerator, including the interior light.

If the refrigerator will not be in operation for a period of weeks, it should be emptied, defrosted, cleaned and the doors left ajar. The ice trays should also be dried and kept outside the cabinet.

TURNING ON THE CLIMATE CONTROL

DM2652, DM2662, DM2663, DM2852, DM2862, NDM1062 & NDR1292



Turn the Climate control switch to I (ON).

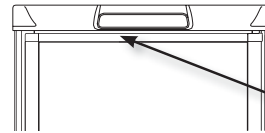

The Climate control switch is located beneath the top decoration panel that houses the control panel.

DM3862, NDM1062 & NDR1292



Press the CLC button. The indicator lamp will illuminate.

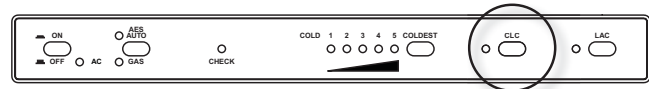

TURNING ON THE LOW AMBIENT CONTROL

NDM1062 & NDR1292



Turn the Low ambient control switch to I (ON).

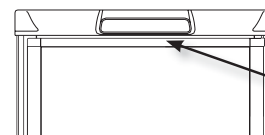

The Low ambient control switch is located beneath the top decoration panel that houses the control panel.

DM3862, NDM1062 & NDR1292



Press the LAC button. The indicator lamp will illuminate.

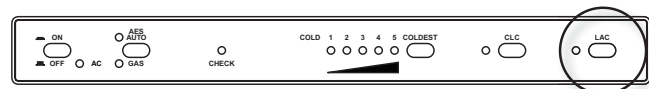

INSTRUCTIONS FOR USE

The following information, "USING THE ICE MAKER", is only valid for refrigerator model NDM1062 equipped with ice maker.

USING THE ICE MAKER

How it works

Before the ice maker can operate, make sure that the:

- Refrigerator is connected to 120 V AC.
- Water valve supplying the refrigerator is turned on.
- Ice level bail arm is in its fully down position.

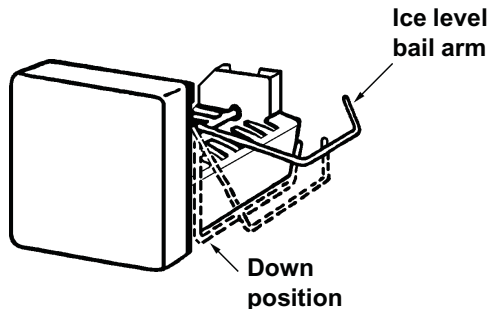

When the ice maker thermostat senses the preset temperature for the ejection of the ice cubes, the fingers will start to rotate, dumping any ice cubes and filling the mold with water. When the storage container is full, the bail arm will come in contact with the ice cubes. The bail arm cannot return to the full down position and the ice production is stopped until the bin is emptied, or ice cubes are removed.

When on the road, the water in the ice maker might, depending on road conditions, splash out of the mold. To avoid splashing, the mold needs to be either empty - or - the water in the mold must be frozen.

Water supply

The water supply system must have a minimum pressure of 15 pounds per square inch gauge (psig). Use a 1/4" diameter water line to the water valve at the rear of the refrigerator. The water line must have a manual shutoff valve placed where it is easily accessible.

The maximum water level is represented by a thin line. It is essential that the water level does not exceed this line!

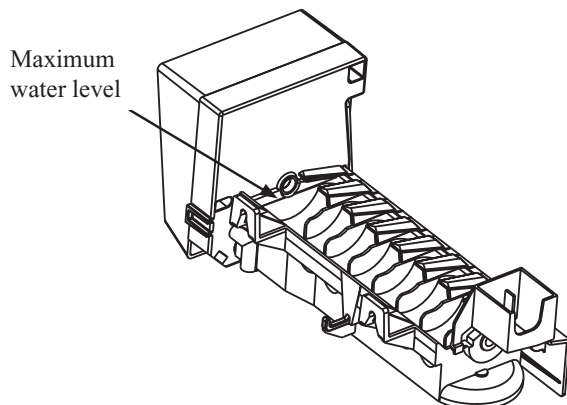

If necessary change the water flow by adjusting the water supply, see the step-by-step instruction in ADJUSTING THE SIZE OF CUBES.

Adjusting the size of cubes

The first container of ice cubes should be dumped if the water system has been winterized or not used for several weeks.

Note that if the ice maker have been cleaned and drained, no ice cubes will be dumped into the bin during the first cycle.

The first few cycles may produce small cubes due to air trapped in the water lines. Once the ice maker has run through several cycles and if the cubes are too small or sticking together, adjustment is necessary on the amount of water entering the mold.

To adjust the size of cubes, follow these steps:

1. Remove the protective cover from the ice maker mechanism.
2. Locate the adjusting screw under the protective cover.

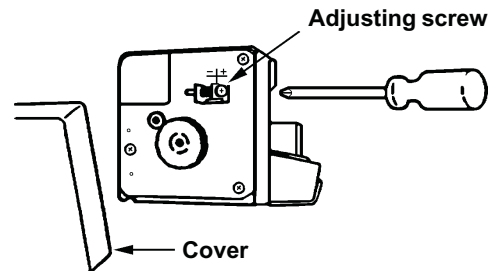

3. To increase the size of cubes, turn the screw counter clockwise. To decrease the cube size or if the cubes are stuck together, turn the screw clockwise.

NOTE! To prevent overfilling, DO NOT turn the adjustment screw more than one revolution at a time. Allow the ice maker to cycle several times before another adjustment is made. Be sure to replace the protective cover on the cycle after the adjustments are complete.

STORAGE COMPARTMENTS

REFRIGERATOR VOLUME

MODEL	TOTAL REFRIGERATED VOLUME (cu.ft)
RM2351 & RM2354	3
RM2451 & RM2454	4
RM2551 & RM2554	5
DM2652, DM2662 & DM2663	6
DM2852, DM2862 & DM3862	8
NDM1062	9.2
NDR1292	12

WARNING

EXPLOSION HAZARD. Never store explosive substances in the refrigerator, such as cigarette lighter fuel, gasoline, ether or the like. Failure to heed this warning could cause an explosion resulting in death or severe personal injury.

FOOD STORAGE COMPARTMENT

- Cool the refrigerator before placing any food inside. Never put hot food or drinks into the refrigerator - cool them first.
- The food storage compartment is completely closed and unventilated, which is necessary to maintain the required low temperature for food storage. Consequently, foods having a strong odor or those that absorb odors easily should be covered.
- Vegetables, salads etc. should be covered to retain their crispness.
- The coldest positions in the refrigerator are under the cooling fins and at the bottom of the refrigerator. The warmer areas are on the upper door shelves. This should be considered when placing different types of food in the refrigerator.
- Arrange all food in the unit to allow for free air circulation. Do not overpack because a stuffed refrigerator must work harder and will have higher cabinet temperatures.
- Do not leave the unit's door open any longer than necessary. This will reduce frost formation and increase the efficiency of the refrigerator.

FROZEN FOOD STORAGE COMPARTMENT

This compartment is not designed for deep or quick freezing of food.

- To prevent food from drying out, keep it in covered dishes, containers, plastic bags or wrapped in aluminum foil.
- Meat or fish, whether raw or prepared, can be stored in the frozen food storage compartment provided they are pre-cooled first in the refrigerator. They can be stored about three times longer in the frozen food compartment as compared to the fresh food compartment.
- Quick frozen soft fruits and ice cream should be placed in the coldest part of the compartment, which is at the bottom of the aluminum liner.
- Frozen vegetables, may be stored in any part of the compartment.
- To prevent frost buildup, which can reduce the efficiency, wipe excess moisture off items being placed in the compartment.

Ice cubes

Ice cubes can be made in the freezer compartment. For faster ice making, the trays should be placed in direct contact with the bottom of the freezer compartment.

RM2351, RM2454, RM2554, DM2662, DM2663, DM2862, DM3862, NDM1062 & NDR1292

Ice will be made more rapidly if the thermostat is set at its highest position, but be sure to move the thermostat back to normal setting when the ice is formed; the refrigerator might otherwise become too cold.

STORAGE COMPARTMENTS

REMOVING AND REPLACING THE SHELVES

1 /

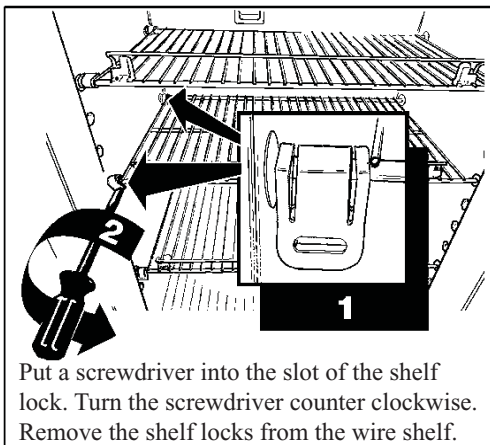

2 /

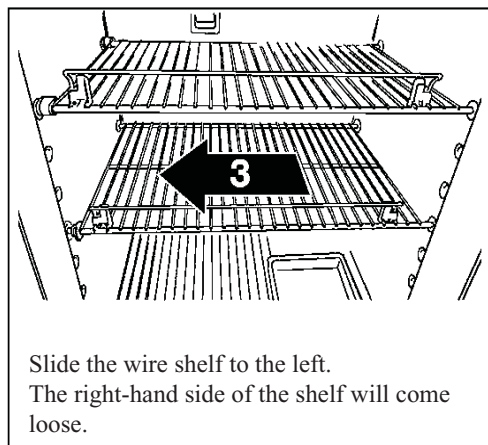

3 /

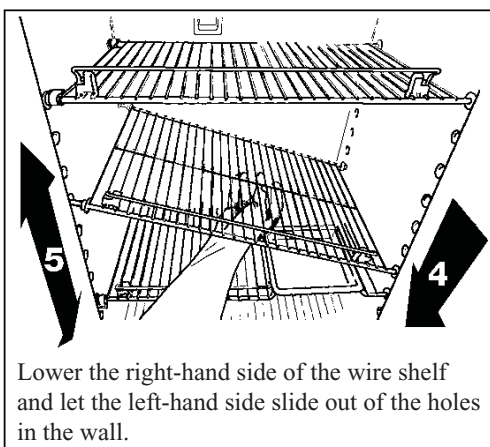

4 /

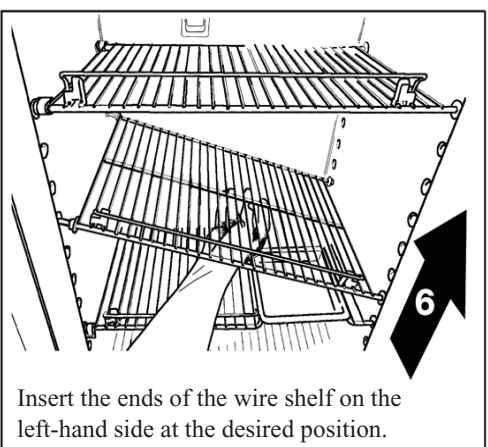

5 /

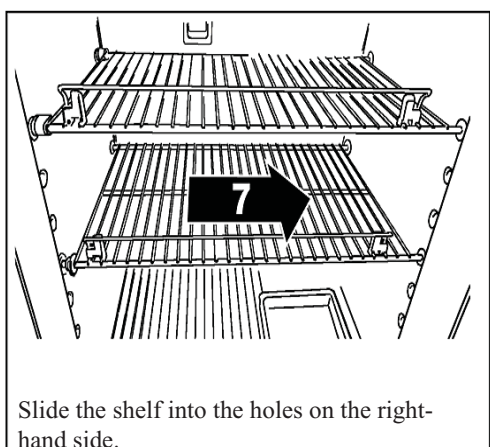

6 /

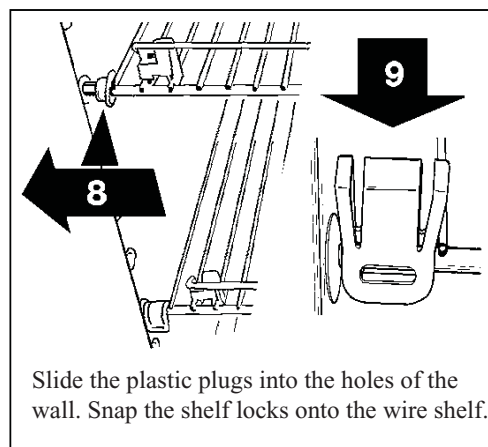

PRODUCT CARE

DEFROSTING

1. Shut off the refrigerator by pressing the main power ON/OFF button (OFF position).
2. Empty the refrigerator.
3. Leave the cabinet and freezer doors open and place the drip tray under the finned evaporator. Defrosting time can be reduced by filling the ice trays with hot water and placing them in the freezer compartment.

CAUTION

Do not use:

- A knife or an ice pick, or other sharp tools to remove frost from the freezer shelves. It can create a leak in the ammonia system.
- A hot air blower. Permanent damage could result from warping the metal or plastic parts.

4. When all the frost has melted, dry the interior with a clean cloth.
5. Turn the refrigerator back on.

The following information, “STORAGE PROCEDURE/WINTERIZING THE REFRIGERATOR”, is only valid for refrigerator model NDM1062 equipped with ice maker.

STORAGE PROCEDURE/WINTERIZING THE REFRIGERATOR

The refrigerator is equipped with a heater tape wrapped around the water solenoid valve and outlet water tube. During cold weather operation below 32°F/0°C the automatic temperature switch will turn the heater tape on automatically.

If the RV will not be in use for an extended period of time or put into storage:

- Drain the RV water system.
- Disconnect the water lines from the inlet and outlet sides of the water valve. Drain the lines into a cup and allow the lines to dry.
- The ice maker should be drained and dried, see DRAINING THE ICE MAKER.
- Using a lukewarm soda solution, clean the interior liner of the refrigerator. Clean the finned evaporator, ice trays and shelves. Use warm water only and never strong chemicals or abrasives since these can damage the protective surfaces.
- Leave the doors ajar.

Draining the ice maker

If the RV is in storage and the refrigerator or the DC power is turned “OFF” there will be no 12V DC present to operate the heat tape; therefore, it will be necessary to drain and dry the ice maker. This will prevent water from freezing in the solenoid valve or becoming stale and producing bad tasting ice.

If the temperatures are expected to reach or exceed 0°F/-18°C the ice maker must be drained to prevent component damage and leaks.

NOTE! Water, compressed air and AC power are required to drain the ice maker. Draining of the ice maker must be done by a qualified service technician.

To drain the ice maker, follow these steps:

1. Shut off water supply valve to the ice maker.
2. Place a shallow pan under water solenoid valve.
3. Remove inlet fitting to ice maker water solenoid valve. Drain water from the supply line.

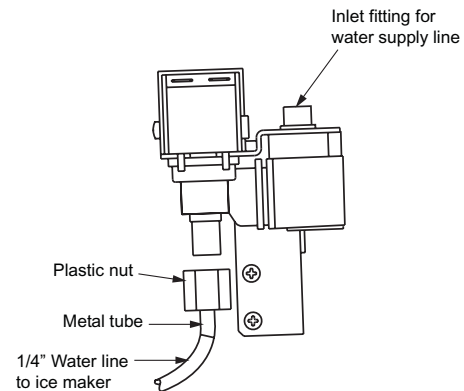

4. Remove the plastic nut and water line from outlet side of the water solenoid valve. Drain water from the line.
5. Connect compressed air onto the inlet fitting of the water solenoid valve.
6. Apply AC power to the solenoid valve by forcing the ice maker mold assembly through several harvest cycles.
7. Remove the plastic cover from the mold assembly. The bail arm must be in the down (“ON”) position.
8. Start the harvest cycle with a flat blade screw driver inserted into the center of the small gear.

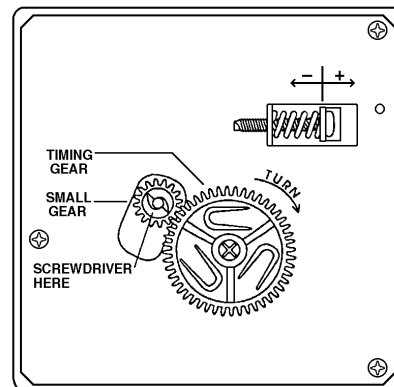

PRODUCT CARE

9. Turn the gear counterclockwise, when the hold switch closes, the mold assembly will continue to operate through the harvest cycle. During the water fill sequence of the harvest cycle the compressed air will blow out the water trapped in the solenoid valve.
10. Repeat the harvest cycle operation several times. Up to 20 PSIG air pressure can be used to clear the solenoid valve. Damage to solenoid can occur if AC power is applied for more than 20 seconds.
11. Make sure that the metal tube is in the plastic water line to the ice maker. Reconnect and tighten lines on water solenoid valve. Leave the water supply turned off until temperatures are above 0°F/-18°C
12. Dry the ice maker mold assembly with a soft cloth.
13. Place bail arm in the "UP/OFF" position.

CLEANING

Always keep the refrigerator clean. Cleaning the refrigerator is usually done after it is defrosted or put into storage. Use lukewarm weak soda solution to clean the interior liner of the refrigerator. Use warm water only to clean the finned evaporator, gasket, ice tray and shelves. Do not spray liquids near electrical outlets, connections or the refrigerator components.

CAUTION

Never use strong chemicals or abrasives to clean these parts, as the protective surfaces will be damaged.

To keep the refrigerator operating efficiently and safely, periodic inspection and cleaning of several components once or twice a year is recommended:

- Check the lower vent, upper vent and area between these openings for any obstructions such as bird/insect nests, spider webs, etc.
- Make sure the refrigerator area is free from combustible material, gasoline and other flammable vapors or liquids.
- Clean the coils on the back of the refrigerator. Use a soft bristled brush to dust off the coils.

REPLACING THE HALOGEN LAMP

DM3862 & NDM1062

CAUTION

Before replacing the lamp, turn off the refrigerator. Wear gloves as protection against hot lamp, broken glass as protection of the new lamp.

The lamp is located at the top of the refrigerator compartment.

To replace the lamp, follow these steps:

1. Remove the lamp cover.
2. Wearing gloves, pull out the lamp from socket. Replace it with a new 12V, 10W halogen lamp base G4.
3. Put back the lamp cover.

AIRING POSITION CARD

DM2652, DM2662, DM2663, DM2852 & DM2862



Use the **Airing Position Card** to keep the doors ajar if the refrigerator will not be in use for an extended period of time or put in storage.

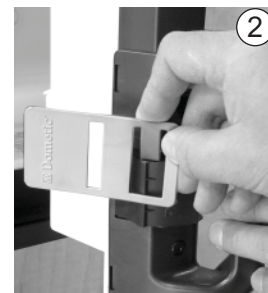

MAINTENANCE & SERVICE



To keep the refrigerator working properly, a qualified service technician should, at least once a year, inspect the connections, the control system, the LP gas pressure and flue baffle. The service and maintenance described in this section is to be performed by service personnel only!

CAUTION

If your refrigerator stops cooling, immediately turn the refrigerator off and see a Dometic dealer.

ELECTRIC EQUIPMENT

Heater

The heat necessary for the operation of an absorption cooling unit is supplied by an electric heater mounted in a pocket of the boiler system.

2-way models are equipped with *one* electrical heater for 120 V AC.

3-way models are equipped with *two* electrical heaters - one for 120V AC and one for 12V DC.

Replacing the heater

To replace the heater, follow these steps:

1. Turn off the refrigerator.
2. Unplug the power cord and disconnect the 12V DC power.
3. Remove the power module cover.
4. Disconnect the heater leads.
5. With a pair of pliers, unfold the lug holding the lid of the boiler casing. Open the lid.
6. Remove some insulation wool for the heater to be accessible.
7. Turn and lift the heater out of its pocket.
8. Fit the new heater into the pocket.
9. Connect the leads and refit the power module cover.
10. Put back the insulation wool.
11. Close the lid of the boiler.

Fuses

2-way models are equipped with 2 fuses - one for the refrigerator control system and one for the AC heater.

3-way models are equipped with 3 fuses - two fuses in the power module and one in-line blade fuse.

Control system	3 A
AC heater	5 A
12 V DC heater	30 A

Replacing the fuses

Power module

To replace the fuses, follow these steps:

1. Turn off the refrigerator.
2. Unplug the power cord and disconnect the 12V wires.
3. Remove the power module cover.
4. Snap the fuse out of the fuse holder.
5. Fit the new fuse in to the fuse holder.
6. Put back the power module cover.

DM2652 (WITH OPTIONAL FAN), DM2852 (WITH OPTIONAL FAN), DM2862 (WITH OPTIONAL FAN), NDM1062 & NDR1292

Inline fuse

The 3 A inline fuse for the power vent fans is connected to the 12V DC socket. To replace the inline fuse, follow these steps:

1. Disconnect 12V DC power.
2. Open the fuse holder.



3. Replace the fuse.



4. Put the holder back together.



MAINTENANCE & SERVICE

PERIODIC MAINTENANCE

Checking the control system

Check the control system by connecting/disconnecting the 120V AC power, starting/stopping the engine, etc.

Checking the connections

1. Check all connections in the LP gas system (at the back of the refrigerator) for gas leaks. The LP gas supply must be turned on.
2. Apply a non-corrosive bubble solution to all LP gas connections. The appearance of bubbles indicates a leak and should be repaired *immediately!*

⚠ WARNING
EXPLOSION HAZARD. Never use an open flame to check for gas leaks. Failure to heed this warning could cause an explosion resulting in death or severe personal injury.

Checking the LP gas pressure

The LP gas pressure should be checked and the main regulator readjusted if pressure is incorrect. The correct operating pressure is 11 inches of water column. Measure the LP gas pressure at the test port, just ahead of the burner jet.

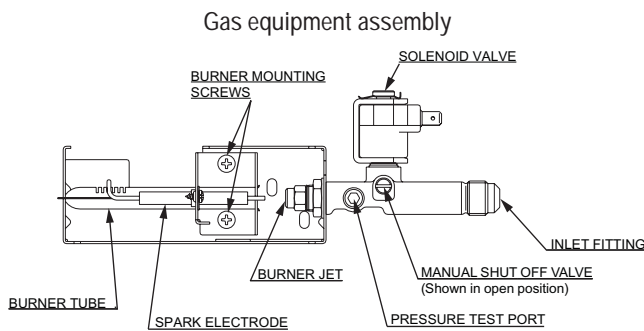

Cleaning the flue baffle and burner

Inspect the flue baffle. It should be reasonably clean and free of soot. Heavy soot formation indicates improper functioning of the burner.

To clean the flue and burner, follow these steps:

1. Turn off the refrigerator.
2. Unplug the power cord from the 120V AC outlet. Disconnect the wires or shut off the 12V DC power supply to the refrigerator.
3. Turn off the manual shut off valve.
4. Remove cover from burner housing. Remove the burner mounting screws and then, the burner assembly.

5. Remove the wire and flue baffle from the top of the flue tube.
6. Using a flue brush, clean the flue from the top. Blowing compressed air into the flue will *not* properly clean soot and scale out of the flue tube.
7. Put back the flue baffle.
8. Clean the burner tube with a brush. Blow out the burner with compressed air.

⚠ WARNING
FIRE HAZARD. Do not use a wire or pin when cleaning the burner jet as damage can occur to the precision opening. Failure to heed this warning could cause fire resulting in personal injury

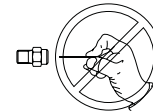

9. Remove burner jet, but first, clean burner area of soot and scale that fell out of flue tube.
10. Remove the burner jet.
11. Soak the jet in wood alcohol and blow it out with compressed air.
12. Reinstall and tighten the burner jet.
13. Reinstall the burner. Ensure the end of the burner fits into the slot on the burner bracket. Verify that the slots are centered under the flue tube and the thermocouple is positioned properly (tip of thermocouple extends over two slots of burner).

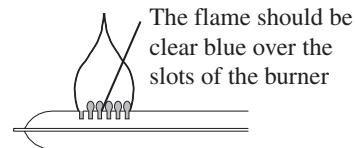

14. Check the electrode for proper location and gap.

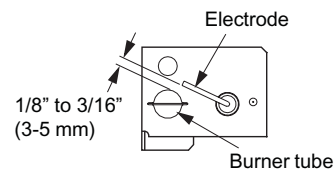

15. Turn on the manual gas shut off valve.
16. Examine all fittings for leaks. (Use a commercial non-corrosive bubble solution.)
17. Connect the 120V power cord. Reconnect/turn on the 12V DC power.
18. Check the LP gas safety shut off.

TROUBLESHOOTING

If you run into a problem, refer to the troubleshooting table below.

Symptom	Check/Remedial action
The refrigerator has stopped cooling.	<ul style="list-style-type: none"> • Immediately turn the refrigerator off and see a Dometic dealer.
Refrigerator or freezer is not cold enough	<ul style="list-style-type: none"> • Is the plug firmly connected to the socket? Is the socket switched on? Check the socket by plugging in another appliance. • Defective fuse? Fit a new fuse. • For refrigerators equipped with thermostat - check if it is properly set. • Is the refrigerator level? Because of its operation it is important to keep an absorption refrigerator level. • Heavy frost build-up on evaporator fins? To prevent frost buildup, which can reduce efficiency, do not leave the unit's door open longer than necessary. • Has the overheating protection been triggered or not? (Must be checked by a qualified service technician.) • Is there a power failure? Are the fuses are intact for the AC supply and control system? • Has the door been closed properly causing the inside temperature to rise to quickly? • Overpacked refrigerator? The unit will have to work harder if the refrigerator is stuffed and results in higher cabinet temperatures. Arrange the food in the unit to allow for free air circulation. • Is the burner dirty, damaged or not properly located under the flue tube? • Is the burner jet clogged? • Is the flue baffle inserted properly in the flue tube? • Is the LP gas pressure low at burner? Set the main regulator to regulate the pressure so it does not drop below 11 inches water column at pressure tap.
Odors from fumes:	<ul style="list-style-type: none"> • Dislocated burner • Damaged burner • Dirty flue tube
The refrigerator does not work in gas operation mode	<ul style="list-style-type: none"> • Gas bottle empty? Change the gas bottle • Air in the gas pipe? Remove the air by switching the refrigerator on and off 3-4 times.

If the problem persists and the refrigerator is still not working properly, contact your nearest Service Center. State the problem, model, product- and serial-number. These details are stated on the data label inside the refrigerator compartment.

APPENDIX A - SPARE PARTS

The following table displays commonly used parts which should be available from your Dometic Service Center.

MODEL \ SPARE PARTS	RM2351	RM2354	RM2451	RM2454	RM2551	RM2554	DM2652
Airing position card	N.A.	N.A.	N.A.	N.A.	N.A.	N.A.	3850781-01
Baffle	2007172-02/2	2007172-02/2	2932667-01/3	2932667-01/3	2932667-02/1	2932667-02/1	2932667-03/9
Bottle holder, 2 pieces	N.A.	N.A.	N.A.	N.A.	N.A.	N.A.	N.A.
Box	2932636-01/8	2932636-01/8	N.A.	N.A.	N.A.	N.A.	N.A.
Box vegetable	N.A.	N.A.	N.A.	N.A.	2932621-01/0	2932621-01/0	2932621-01/0
Box vegetable (crisper)	N.A.	N.A.	N.A.	N.A.	N.A.	N.A.	N.A.
Box vegetable (crisper)	N.A.	N.A.	N.A.	N.A.	N.A.	N.A.	N.A.
Box vegetable (crisper), 2 pieces	N.A.	N.A.	N.A.	N.A.	N.A.	N.A.	N.A.
Box vegetable (meat locker)	N.A.	N.A.	N.A.	N.A.	N.A.	N.A.	N.A.
Burner (with conductor)	2930697-07/9	2930697-07/9	2930697-07/9	2930697-07/9	2930697-07/9	2930697-07/9	2930697-07/9
Door reversing kit, (light brown)	3850304-01/9	3850304-01/9	N.A.	N.A.	N.A.	N.A.	N.A.
Door reversing kit, (black)	3850304-02/7	3850304-02/7	N.A.	N.A.	N.A.	N.A.	N.A.
Door reversing kit, right-left (light brown)	N.A.	N.A.	2932750-02/5	2932750-02/5	2932750-02/5	2932750-02/5	2932750-08/2
Door reversing kit, left-right (light brown)	N.A.	N.A.	2932750-03/3	2932750-03/3	2932750-03/3	2932750-03/3	2932750-09/0
Door reversing kit, right-left (black)	N.A.	N.A.	2932750-13/2	2932750-13/2	2932750-13/2	2932750-13/2	2932750-11/6
Door reversing kit, left-right (black)	N.A.	N.A.	2932750-14/0	2932750-14/0	2932750-14/0	2932750-14/0	2932750-12/4
Door shelf, lower	N.A.	N.A.	2932575-01/8	2932575-01/8	2932575-01/8	2932575-01/8	2932575-01/8
Door shelf, 2 pieces	N.A.	N.A.	2932576-01/6	2932576-01/6	N.A.	N.A.	2932576-01/6
Door shelf, 3 pieces	2002261-24/2	2002261-24/2	N.A.	N.A.	2932576-01/6	2932576-01/6	N.A.
Door shelf, freezer	N.A.	N.A.	N.A.	N.A.	N.A.	N.A.	2932577-01/4
Door shelf, 6 pieces	N.A.	N.A.	N.A.	N.A.	N.A.	N.A.	N.A.
Electrode	2932781-01/2	2932781-01/2	2932781-01/2	2932781-01/2	2932781-01/2	2932781-01/2	2932781-01/2
Halogen lamp (12V, 10W base G4)	N.A.	N.A.	N.A.	N.A.	N.A.	N.A.	N.A.
Handle (light brown)	N.A.	N.A.	2932670-01/7	2932670-01/7	2932670-01/7	2932670-01/7	2932093-01/2
Handle (black)	N.A.	N.A.	2932670-02/5	2932670-02/5	2932670-02/5	2932670-02/5	2932093-03/8
Heater 175W, 12V	N.A.	3850646-10/4	N.A.	3850646-10/4	N.A.	3850646-10/4	N.A.
Heater 175W, 120V	3850644-45/5	3850644-45/5	3850644-45/5	3850644-45/5	3850644-45/5	3850644-45/5	N.A.
Heater 275W, 12V	N.A.	N.A.	N.A.	N.A.	N.A.	N.A.	N.A.
Heater 325W, 120V	N.A.	N.A.	N.A.	N.A.	N.A.	N.A.	3850644-42/2
Heater 420W, 120V (2 x 60V, 201W)	N.A.	N.A.	N.A.	N.A.	N.A.	N.A.	N.A.
Jet, No. 39	2007419-15/9	2007419-15/9	N.A.	N.A.	N.A.	N.A.	N.A.
Jet, No. 43	N.A.	N.A.	2007419-16/7	2007419-16/7	2007419-16/7	2007419-16/7	N.A.
Jet, No. 58	N.A.	N.A.	N.A.	N.A.	N.A.	N.A.	2007419-21/7
Jet, No. 76	N.A.	N.A.	N.A.	N.A.	N.A.	N.A.	N.A.
Lamp cover	N.A.	N.A.	N.A.	N.A.	N.A.	N.A.	2932106-01/2

APPENDIX A - SPARE PARTS

MODEL \ SPARE PARTS	DM2662	DM2663	DM2852	DM2862	DM3862	NDM1062	NDR1292
Airing position card	3850781-01	3850781-01	3850781-01	3850781-01	N.A.	N.A.	N.A.
Baffle	2932667-03/9	2932667-03/9	2932667-04/7	2932667-04/7	2932667-04/7	2932667-04/7	2932667-05/4
Bottle holder, 2 pieces	N.A.	N.A.	N.A.	N.A.	N.A.	N.A.	2932658-01/2
Box	N.A.	N.A.	N.A.	N.A.	N.A.	N.A.	N.A.
Box vegetable	2932621-07/7	2932621-07/7	2932621-01/0	2932621-07/7	2932621-09/3	N.A.	N.A.
Box vegetable (crisper)	N.A.	N.A.	N.A.	N.A.	N.A.	N.A.	2002726-12/9
Box vegetable (crisper)	N.A.	N.A.	N.A.	N.A.	N.A.	N.A.	2002726-13/7
Box vegetable (crisper), 2 pieces	N.A.	N.A.	N.A.	N.A.	N.A.	2002726-17/8	N.A.
Box vegetable (meat locker)	N.A.	N.A.	N.A.	N.A.	N.A.	2932621-08/5	2002726-14/5
Burner (with conductor)	2930697-07/9	2930697-07/9	2930697-07/9	2930697-07/9	2930697-07/9	2930697-07/9	2930697-07/9
Door reversing kit, (light brown)	N.A.	N.A.	N.A.	N.A.	N.A.	N.A.	N.A.
Door reversing kit, (black)	N.A.	N.A.	N.A.	N.A.	N.A.	N.A.	N.A.
Door reversing kit, right-left (light brown)	N.A.	N.A.	2932750-08/2	N.A.	N.A.	N.A.	N.A.
Door reversing kit, left-right (light brown)	N.A.	N.A.	2932750-09/0	N.A.	N.A.	N.A.	N.A.
Door reversing kit, right-left (black)	2932750-11/6	2932750-11/6	2932750-11/6	2932750-11/6	N.A.	2932750-11/6	N.A.
Door reversing kit, left-right (black)	2932750-12/4	2932750-12/4	2932750-12/4	2932750-12/4	N.A.	2932750-12/4	N.A.
Door shelf, lower	2932575-05/9	2932575-05/9	2932575-01/8	2932575-05/9	2932575-06/7	2932575-07/5	N.A.
Door shelf, 2 pieces	2932576-06/5	2932576-06/5	N.A.	N.A.	N.A.	N.A.	N.A.
Door shelf, 3 pieces	N.A.	N.A.	2932576-01/6	2932576-06/5	2932576-07/3	2932576-08/1	N.A.
Door shelf, freezer	N.A.	N.A.	2932577-01/4	N.A.	N.A.	N.A.	2932577-02/2
Door shelf, 6 pieces	N.A.	N.A.	N.A.	N.A.	N.A.	N.A.	2932583-03/8
Electrode	2932781-01/2	2932781-01/2	2932781-01/2	2932781-01/2	2932781-01/2	2932781-01/2	2932781-02/0
Halogen lamp (12V, 10W base G4)	N.A.	N.A.	N.A.	N.A.	3850455-01/9	3850455-01/9	N.A.
Handle (light brown)	N.A.	N.A.	N.A.	N.A.	N.A.	N.A.	N.A.
Handle (black)	2932093-03/8	2932093-03/8	2932093-03/8	2932093-03/8	N.A.	2932094-04/4	N.A.
Heater 175W, 12V	N.A.	N.A.	N.A.	N.A.	N.A.	N.A.	N.A.
Heater 175W, 120V	N.A.	N.A.	N.A.	N.A.	N.A.	N.A.	N.A.
Heater 275W, 12V	N.A.	3850646-09/6	N.A.	N.A.	N.A.	N.A.	N.A.
Heater 325W, 120V	3850644-42/2	3850644-42/2	3850644-42/2	3850644-42/2	3850644-42/2	3850644-42/2	N.A.
Heater 420W, 120V (2 x 60V, 210W)	N.A.	N.A.	N.A.	N.A.	N.A.	N.A.	3850644-46/3
Jet, No. 39	N.A.	N.A.	N.A.	N.A.	N.A.	N.A.	N.A.
Jet, No. 43	N.A.	N.A.	N.A.	N.A.	N.A.	N.A.	N.A.
Jet, No. 58	2007419-21/7	2007419-21/7	2007419-21/7	2007419-21/7	2007419-21/7	2007419-21/7	N.A.
Jet, No. 76	N.A.	N.A.	N.A.	N.A.	N.A.	N.A.	2007419-33/2
Lamp cover	2932106-01/2	2932106-01/2	2932106-01/2	2932106-01/2	3850532-01/5	3850532-01/5	2932106-01/2

APPENDIX B - CONSUMER SUPPORT

Dometic website

www.dometicus.com

Please visit the website for information and news about Dometic products. You can obtain information about how to get in contact, learn about product care, download manuals, leaflets and warranties.

Service and spare parts

For service, please contact the Service Center Assistance, see the front page of this manual - or - visit the Dometic website to find the location of the nearest Dometic Service Center.

Commonly used spare parts are listed in this manual, see APPENDIX A - SPARE PARTS. These should be available from your Dometic Service Center.

Contact us

For contact information, please see the frontpage of this manual - or - visit the Dometic website.

Register the appliance

www.edometric.com

Timely registration will allow for enhanced communication and service under the terms of the warranty, see APPENDIX C - DOMETIC WARRANTY & MAINTENANCE SCHEDULE.

To register the appliance, fill in the pre-printed registration card on the last page of this manual or register on-line at the Dometic website www.edometric.com.

To register on-line, follow these steps:

1. At www.edometric.com, click **Warranty Registration**.



2. Click **Register your new Dometic product here**.



3. Complete the information and then, click the **Submit Registration** button.

A screenshot of the 'Dometic Owner's Registration' form. The form is titled 'Dometic Owner's Registration' and includes the following fields: First, M, Last; Street; City, State/Prov, Zip, Canadian Zip; Model Number, Serial Number, Date of Purchase; and Optional information: E-Mail Address, Home Phone, Work Phone. The 'Model Number' and 'Serial Number' fields are circled in red. A 'SUBMIT Registration' button is at the bottom.

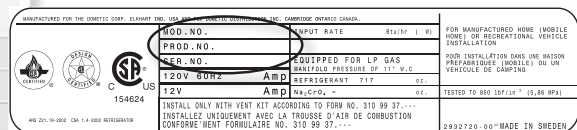

The model number (e.g. RM3762) and serial number (e.g. 012 34567) are stated on the data label in the refrigerator compartment.

APPENDIX C - DOMETIC WARRANTY & MAINTENANCE SCHEDULE

IMPORTANT!

Valuable Dometic Refrigerator Warranty & Maintenance Schedule

Congratulations, and Thank You for purchasing the industry's best built and best backed RV Refrigerator. Enclosed you will find important warranty and maintenance information on Dometic's exclusive three (3) year warranty. Please take a few moments and familiarize yourself with the program. We at Dometic appreciate your business and are confident that you will have many years of trouble-free RV enjoyment.

LIMITED THREE-YEAR WARRANTY DOMETIC REFRIGERATORS

THE SELLER NAMED BELOW MAKES THE FOLLOWING WARRANTY WITH RESPECT TO THE DOMETIC PRODUCT:

1. This warranty is made only to the first purchaser (herein after referred to as the "Original Purchaser") who acquires the product for his own use and is installed and operated within the continental United States and Canada.
2. This warranty will be in effect for three years on parts and freight and two years on labor from the date of purchase by the Original Purchaser. It is suggested that the original purchaser retain a copy of the dated bill of sale as evidence of the date of purchase.
3. This warranty covers only specified parts, which shall be free from defects in material and workmanship under normal use. This warranty does not cover conditions unrelated to the material and workmanship of the product. Such unrelated conditions include, but are not limited to: (a) damage not reported within the first 7 days of ownership; (b) faulty installation or installation that does not comply with RVIA standards, and any damage resulting from such; (c) the need for normal maintenance and any damage resulting from the failure to provide such maintenance; (d) failure to follow Sellers instructions for use of product; (e) any accident to or misuse of any part of this product and any alteration by anyone other than the Seller or its authorized representative; (f) any non-Dometic parts that are installed as replacement parts will void any warranty (implied or written); (g) blow out conditions; (h) radio frequency interference and electromagnetic interference; (i) 12V system chassis ground decay and corrosion; (j) puncture of foam cabinet or vacuum insulated panels after acknowledged receipt; (k) animal or insect infiltration which damages unit or inhibits performance; (l) abuse or misuse of electrical components.
4. The specified parts covered by this warranty are as follows: Major components (cooling unit, LP gas valve, burner, burner housing, electronic display, electronic module, evaporator fins, foam integrity, frame, thermister, spark probe, ignition wire, icemaker compressor, second absorption loop, display escutcheon, lower toe plate, humidity switch, frame heater mullion, icemaker mullion) are covered for parts and freight for three years and labor for two years from date of purchase. All other components that fail must be reported within the first 90 days of ownership in order to receive coverage of parts, freight and labor under warranty.
5. **This warranty requires the Original Purchaser to provide preventative maintenance on a yearly basis, starting at the anniversary of his date of purchase.** The Original Purchaser must keep a record of the preventative maintenance to keep the warranty in effect. Failure of the Original Purchaser in providing this annual maintenance may void the warranty. The preventative maintenance must be performed at a Dometic Authorized Service Center/Dealer. The preventative maintenance required is an inspection, cleaning and full diagnostics performed on the entire electronic system, burner assembly, wiring and cooling unit. A copy of the receipt covering the maintenance checks must accompany the warranty claim during the second and third year of ownership. The cost of this preventative maintenance is the Original Purchaser's responsibility and should take about one hour.
6. In order to obtain the benefits of this warranty, the original purchaser must return the product which is found defective to the Seller named below or to a Dometic Authorized Service Center during the period that this warranty is in effect. The original purchaser is responsible for all charges incurred in delivery of the product to the Seller or Dometic Authorized Service Center, and in pick up after the warranty service has been completed. To obtain the location of the nearest Authorized Service Center, please call 1-800-544-4881 or in Canada call 1-519-720-9578.
7. Any item returned in the manner described in paragraph 6 will be examined by the Seller or the Authorized Dometic Service Center. If it is found that the returned item was defective in material and workmanship, the Seller or the Authorized Dometic Service Center will repair the product per the terms outlined in paragraph 4. **CONFIRM THE SERVICE AGENCY IS AN AUTHORIZED DOMETIC SERVICE CENTER. DO NOT PAY THE SERVICE AGENCY FOR WARRANTY REPAIRS. SUCH PAYMENTS WILL NOT BE REIMBURSED.**
8. The Seller does not authorize any person or company to create any warranty obligations or liability on their behalf. This warranty is not extended by the length of time which you are deprived of the use of the product. Repairs and replacement parts provided under the terms of this warranty shall carry only the non-expired portion of this warranty.
9. In no event shall either seller be liable for incidental or consequential damages. This includes any damage to another product or products resulting from such a defect. Some states do not allow the exclusion or limitation of incidental or consequential damages, so the above limitations may not apply.
10. Any implied warranty, including the implied warranty of merchantability and fitness for any purpose, is limited to the duration of this limited warranty. Some states do not allow limitations on how long an implied warranty can last, so the above limitation may not apply.
11. **THIS WARRANTY GIVE SPECIFIC LEGAL RIGHTS, YOU MAY ALSO HAVE OTHER RIGHTS WHICH VARY FROM STATE TO STATE.** No action to enforce this warranty shall be commenced later than ninety (90) days after the expiration of the warranty period. Claims must be submitted in writing to the Dometic Warranty Department for arbitration.
12. All products (except those specifically built for commercial use) are warranted only when installed on vehicles built to R.V.I.A and C.R.V.A, Z-240 Standards.
13. The Seller reserves the right to change the design of any product without notice and with no obligation to make corresponding changes in products previously manufactured.

DOMETIC, LLC
Warranty Department
2320 Industrial Parkway
Elkhart, IN 46516
Phone: 574-294-2511
Fax: 574-293-9686

REFRIGERATOR OWNER MAINTENANCE YEARLY RECORD

Customer Name: _____ **Model No.:** _____ **Date of Purchase:** _____
Address: _____ **Serial No.:** _____
City: _____ **State:** _____ **Zip Code:** _____
Phone: _____

FIRST YEAR	SECOND YEAR																																										
Date: _____	Date: _____																																										
Dealership: _____	Dealership: _____																																										
Address: _____	Address: _____																																										
City: _____	City: _____																																										
State: _____ Zip: _____	State: _____ Zip: _____																																										
Phone: _____	Phone: _____																																										
Technician: _____	Technician: _____																																										
Cleaned Burner Assembly: Yes / No Cleaned/Check All Terminals Connections: Yes / No Cleaned/Inspect All Ground Connections: Yes / No Inspect and Test Door Seals: Yes / No Inspect and Tighten LP Lines: Yes / No Power Ventilator Installed: Yes / No *Gas Safety Shutdown in 45 seconds: Yes / No	Cleaned Burner Assembly: Yes / No Cleaned/Check All Terminals Connections: Yes / No Cleaned/Inspect All Ground Connections: Yes / No Inspect and Test Door Seals: Yes / No Inspect and Tighten LP Lines: Yes / No Power Ventilator Installed: Yes / No *Gas Safety Shutdown in 45 seconds: Yes / No																																										
<table style="width: 100%; border-collapse: collapse;"> <thead> <tr> <th style="width: 60%;"></th> <th style="width: 20%; text-align: center;">ACTUAL</th> <th style="width: 20%; text-align: center;">SPEC. RANGE</th> </tr> </thead> <tbody> <tr> <td>Electrode Gap</td> <td style="text-align: center;">_____</td> <td style="text-align: center;">3/16"</td> </tr> <tr> <td>Thermister Reading</td> <td style="text-align: center;">_____</td> <td style="text-align: center;">7-10,000 ohms @ 32°</td> </tr> <tr> <td>*D/C Voltage</td> <td style="text-align: center;">_____</td> <td style="text-align: center;">9.5 to 15 volts D/C</td> </tr> <tr> <td>*A/C Voltage</td> <td style="text-align: center;">_____</td> <td style="text-align: center;">120 Volts ± 10%</td> </tr> <tr> <td>Thermocouple Reading</td> <td style="text-align: center;">_____</td> <td style="text-align: center;">25-35 Millivolts</td> </tr> <tr> <td>*Delay Between Modes</td> <td style="text-align: center;">_____</td> <td style="text-align: center;">Approx. 5 seconds</td> </tr> </tbody> </table>		ACTUAL	SPEC. RANGE	Electrode Gap	_____	3/16"	Thermister Reading	_____	7-10,000 ohms @ 32°	*D/C Voltage	_____	9.5 to 15 volts D/C	*A/C Voltage	_____	120 Volts ± 10%	Thermocouple Reading	_____	25-35 Millivolts	*Delay Between Modes	_____	Approx. 5 seconds	<table style="width: 100%; border-collapse: collapse;"> <thead> <tr> <th style="width: 60%;"></th> <th style="width: 20%; text-align: center;">ACTUAL</th> <th style="width: 20%; text-align: center;">SPEC. RANGE</th> </tr> </thead> <tbody> <tr> <td>Electrode Gap</td> <td style="text-align: center;">_____</td> <td style="text-align: center;">3/16"</td> </tr> <tr> <td>Thermister Reading</td> <td style="text-align: center;">_____</td> <td style="text-align: center;">7-10,000 ohms @ 32°</td> </tr> <tr> <td>*D/C Voltage</td> <td style="text-align: center;">_____</td> <td style="text-align: center;">9.5 to 15 volts D/C</td> </tr> <tr> <td>*A/C Voltage</td> <td style="text-align: center;">_____</td> <td style="text-align: center;">120 Volts ± 10%</td> </tr> <tr> <td>Thermocouple Reading</td> <td style="text-align: center;">_____</td> <td style="text-align: center;">25-35 Millivolts</td> </tr> <tr> <td>*Delay Between Modes</td> <td style="text-align: center;">_____</td> <td style="text-align: center;">Approx. 5 seconds</td> </tr> </tbody> </table>		ACTUAL	SPEC. RANGE	Electrode Gap	_____	3/16"	Thermister Reading	_____	7-10,000 ohms @ 32°	*D/C Voltage	_____	9.5 to 15 volts D/C	*A/C Voltage	_____	120 Volts ± 10%	Thermocouple Reading	_____	25-35 Millivolts	*Delay Between Modes	_____	Approx. 5 seconds
	ACTUAL	SPEC. RANGE																																									
Electrode Gap	_____	3/16"																																									
Thermister Reading	_____	7-10,000 ohms @ 32°																																									
*D/C Voltage	_____	9.5 to 15 volts D/C																																									
*A/C Voltage	_____	120 Volts ± 10%																																									
Thermocouple Reading	_____	25-35 Millivolts																																									
*Delay Between Modes	_____	Approx. 5 seconds																																									
	ACTUAL	SPEC. RANGE																																									
Electrode Gap	_____	3/16"																																									
Thermister Reading	_____	7-10,000 ohms @ 32°																																									
*D/C Voltage	_____	9.5 to 15 volts D/C																																									
*A/C Voltage	_____	120 Volts ± 10%																																									
Thermocouple Reading	_____	25-35 Millivolts																																									
*Delay Between Modes	_____	Approx. 5 seconds																																									
* Use PAL RV Diagnostic Tool for these tests.	* Use PAL RV Diagnostic Tool for these tests.																																										
ICEMAKER MODELS	ICEMAKER MODELS																																										
Inspect Water Valve and All Connections: Yes / No	Inspect Water Valve and All Connections: Yes / No																																										
Inspect Heat Tape Switch for Proper Operation: Yes / No	Inspect Heat Tape Switch for Proper Operation: Yes / No																																										

APPENDIX D - REARVIEW EQUIPMENT

RM2351

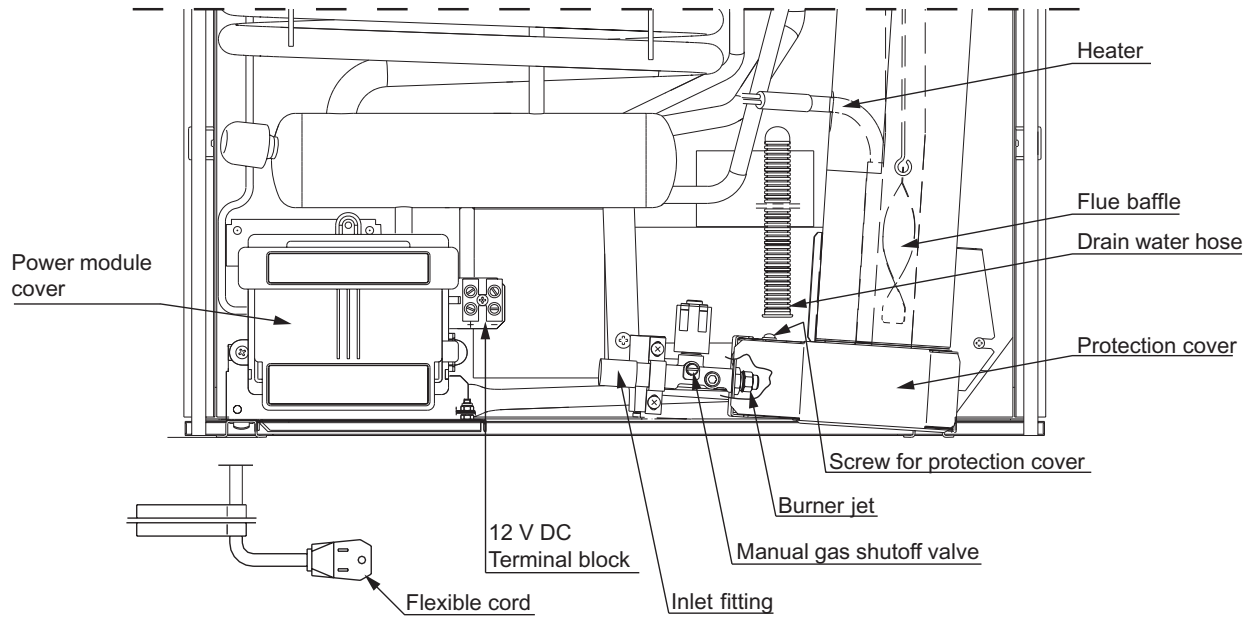

RM2354

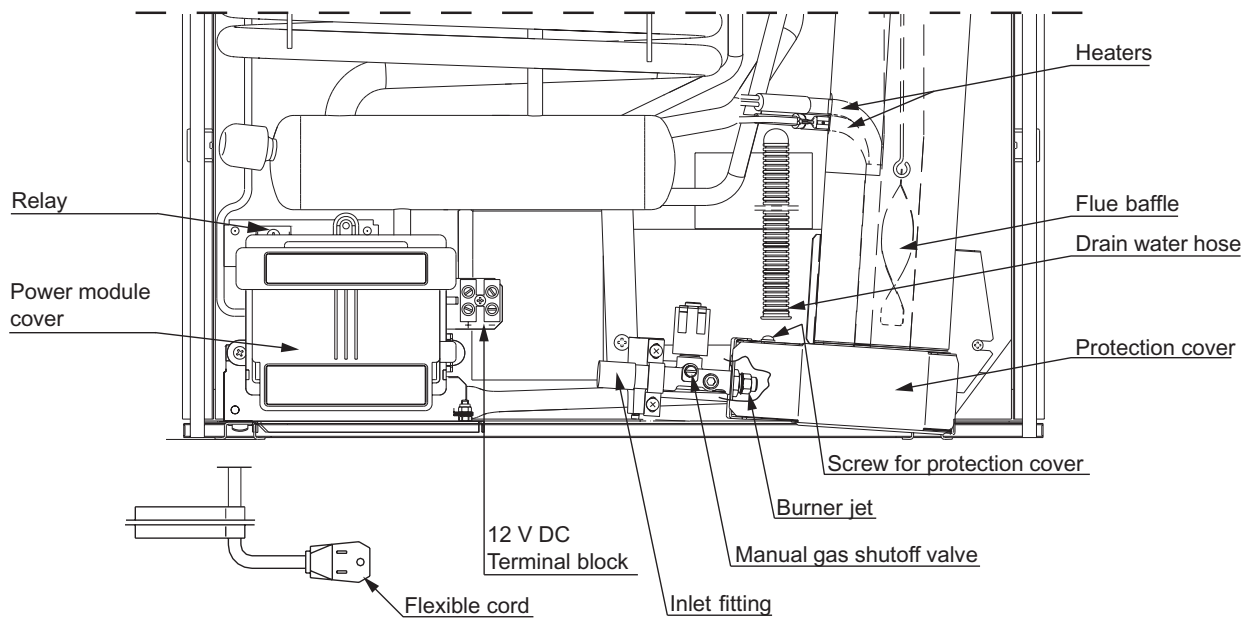

APPENDIX D - REARVIEW EQUIPMENT

RM2451, RM2454, RM2551 & RM2554

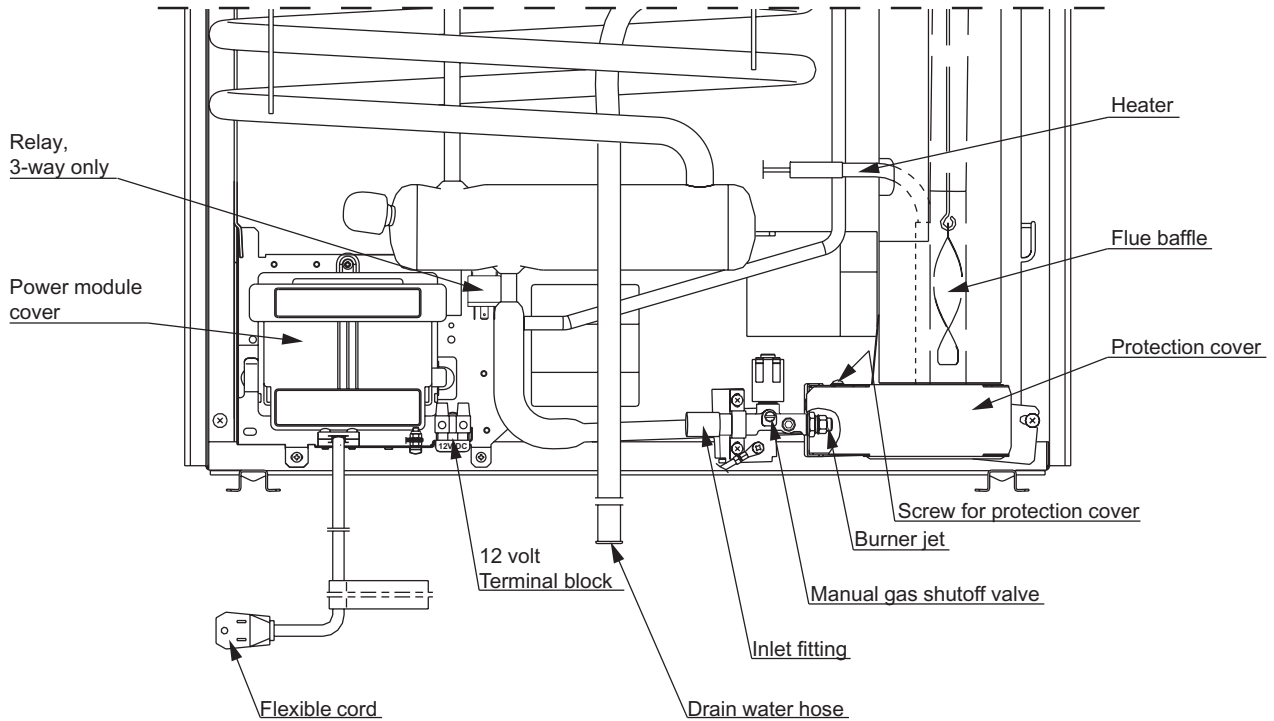

DM2652, DM2662, DM2663, DM2852, DM2862, DM3862 & NDM1062

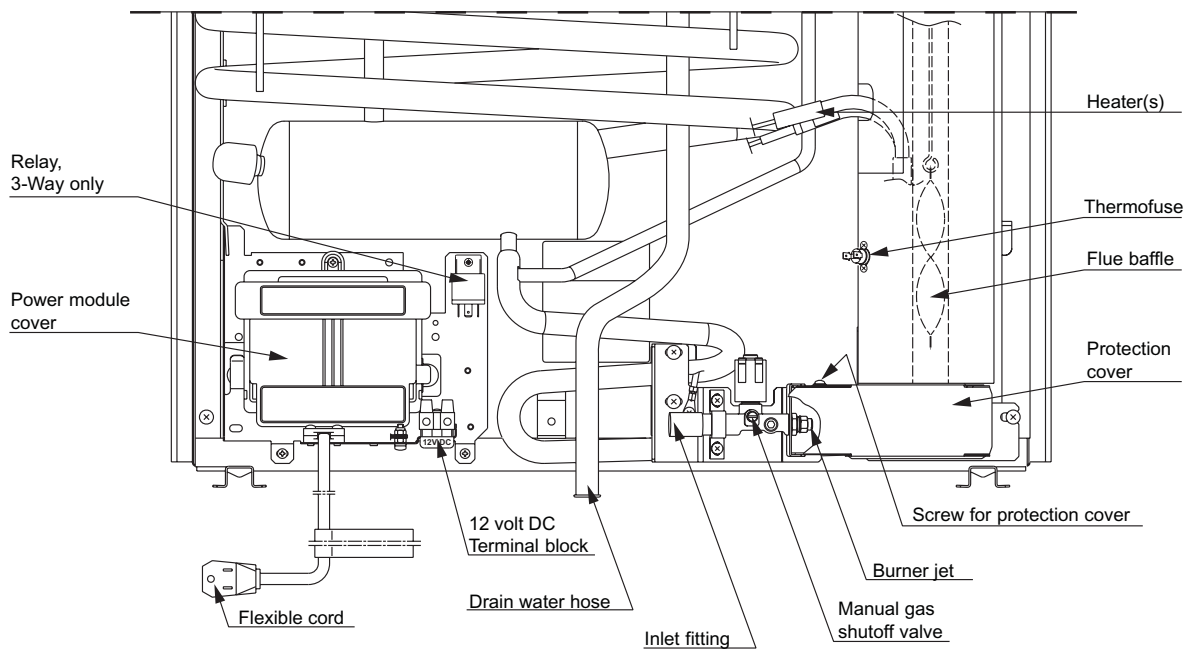

APPENDIX D - REARVIEW EQUIPMENT

NDM1062 (WITH ICE MAKER)

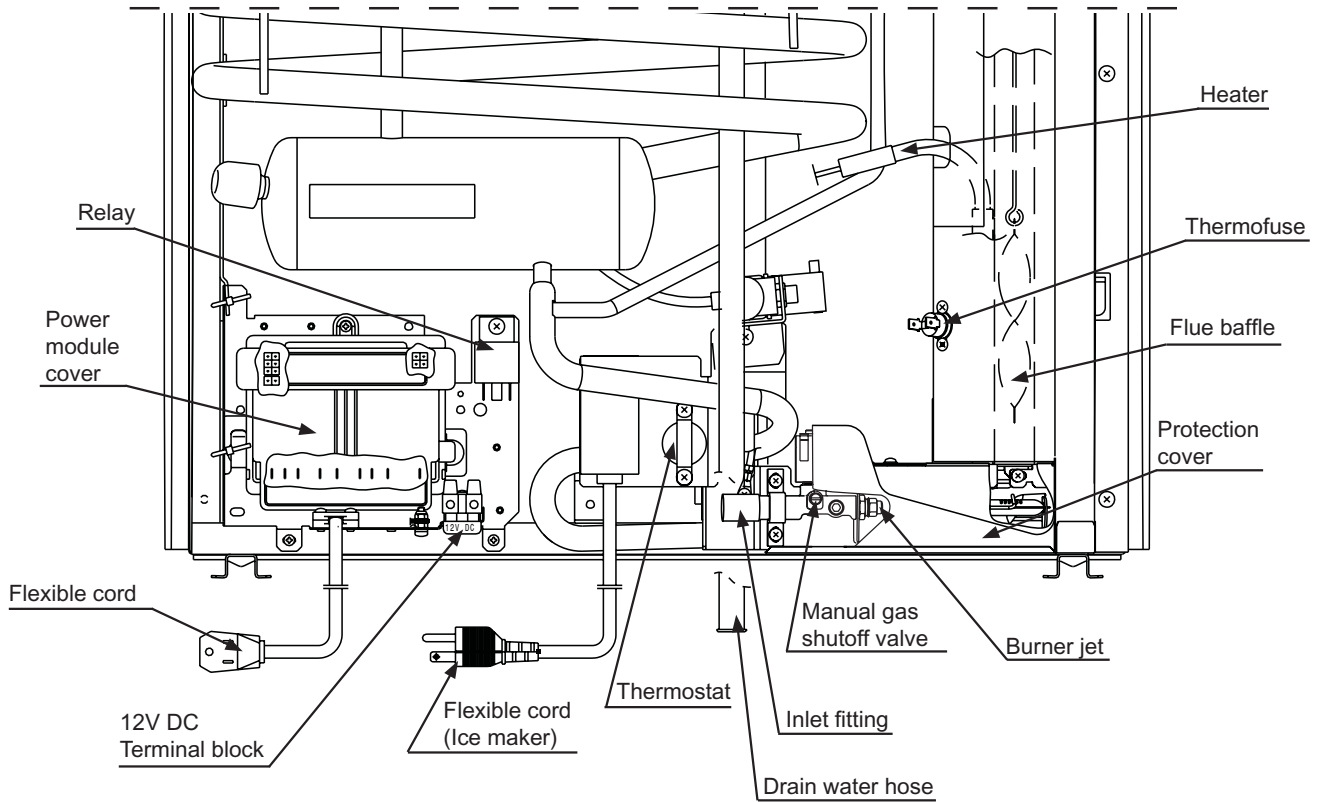

NDR1292

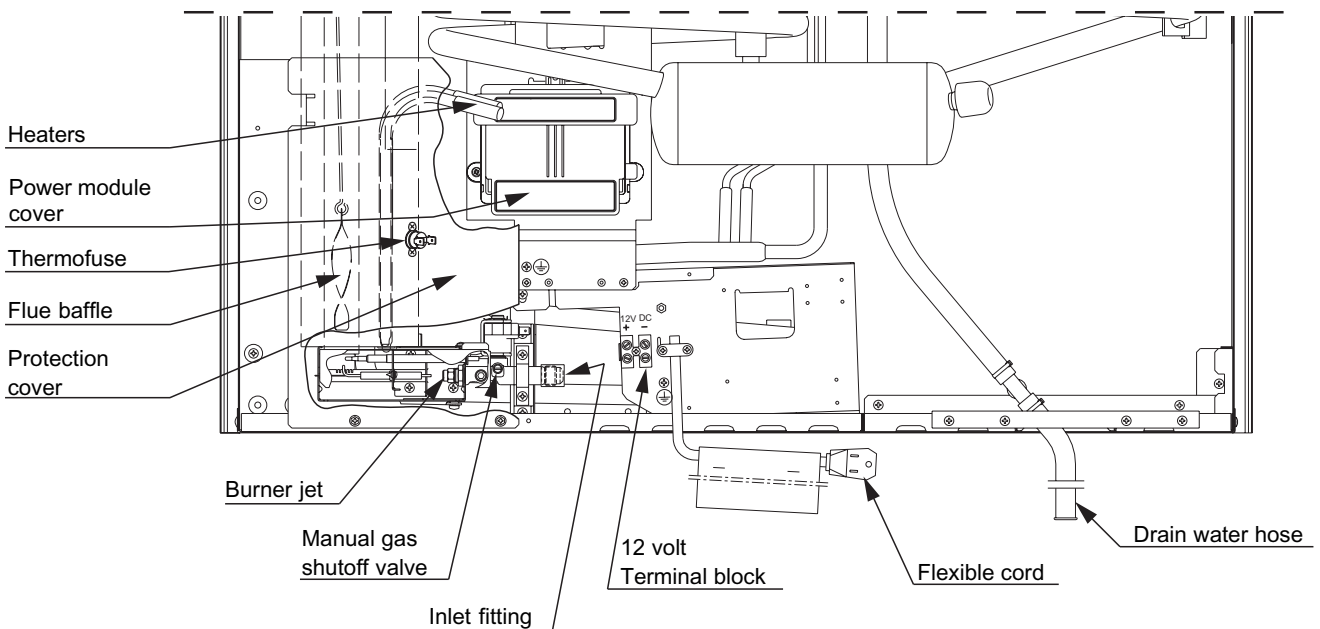

APPENDIX E - WIRING DIAGRAMS

RM2351, RM2451 & RM2551

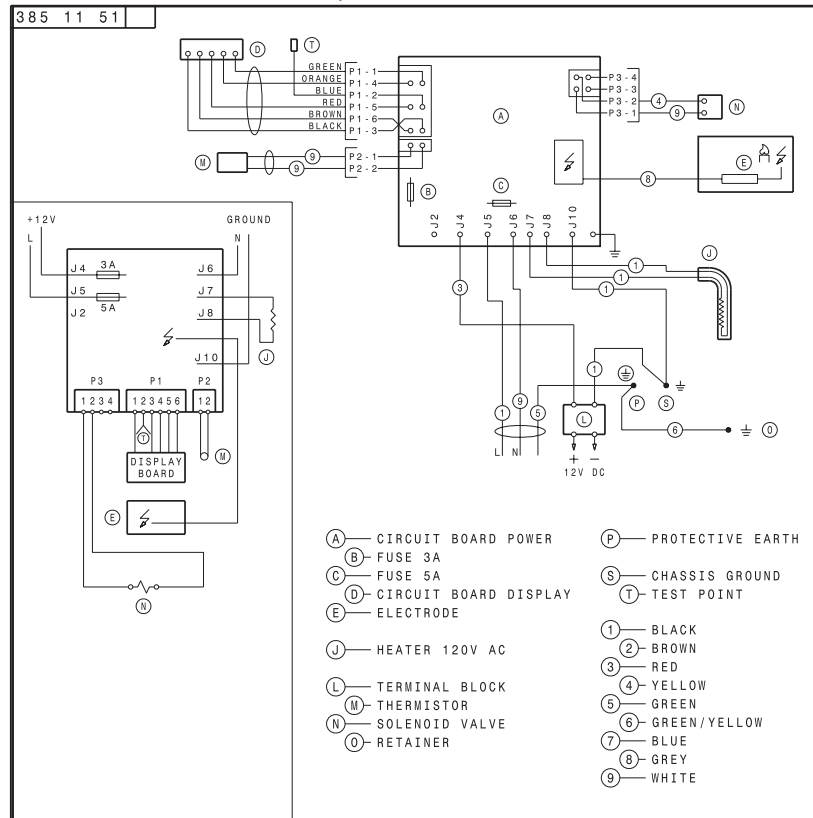

RM2354, RM2454 & RM2554

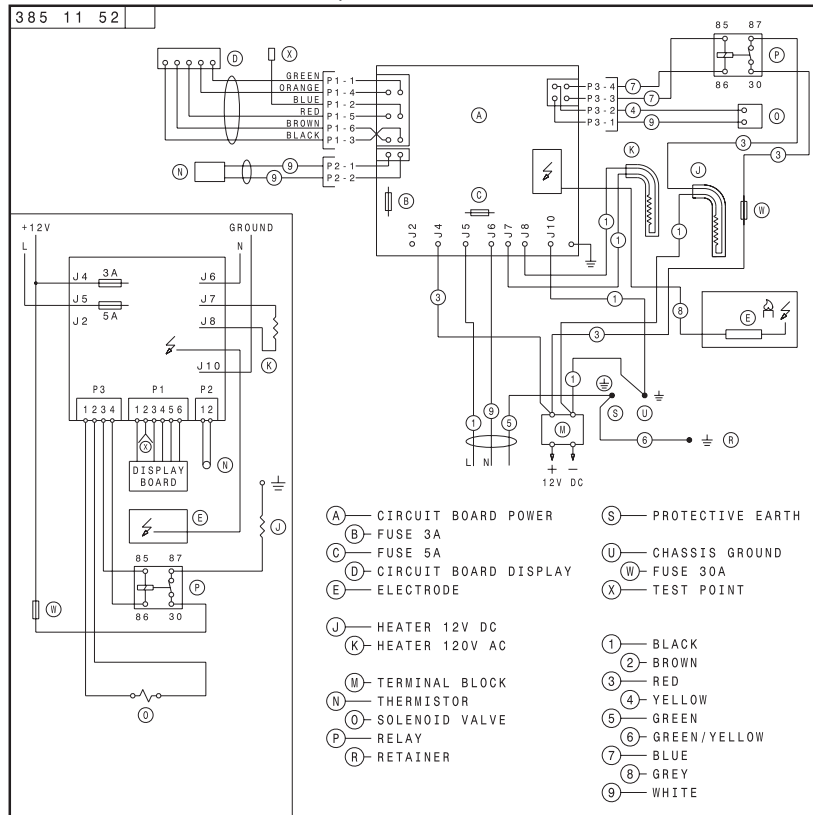

APPENDIX E - WIRING DIAGRAMS

DM2652, DM2662, DM2852 & DM2862

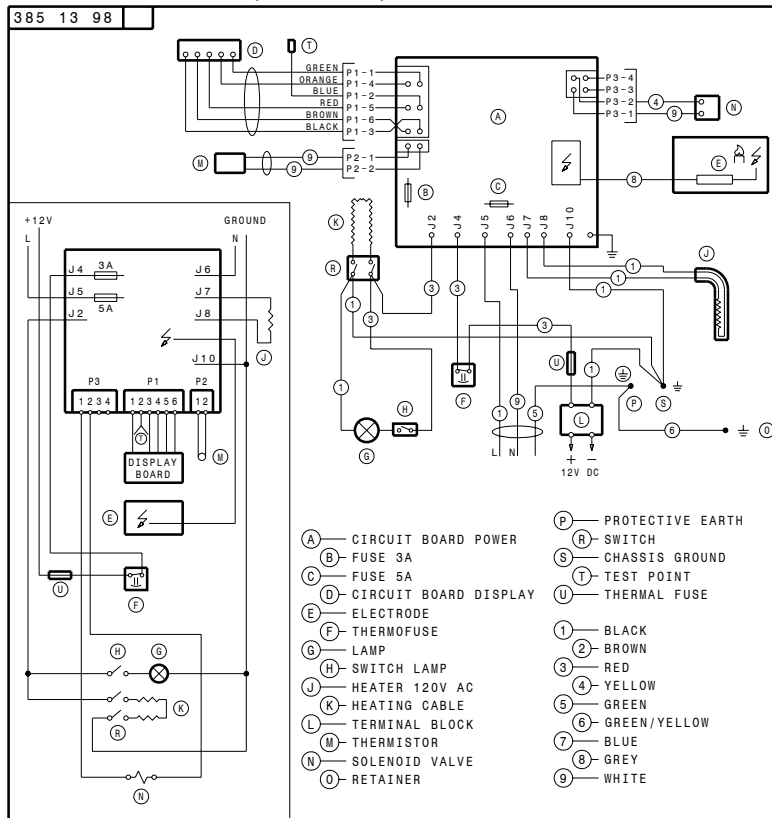

DM2652, DM2852 & DM2862 MODELS EQUIPPED WITH OPTIONAL FAN

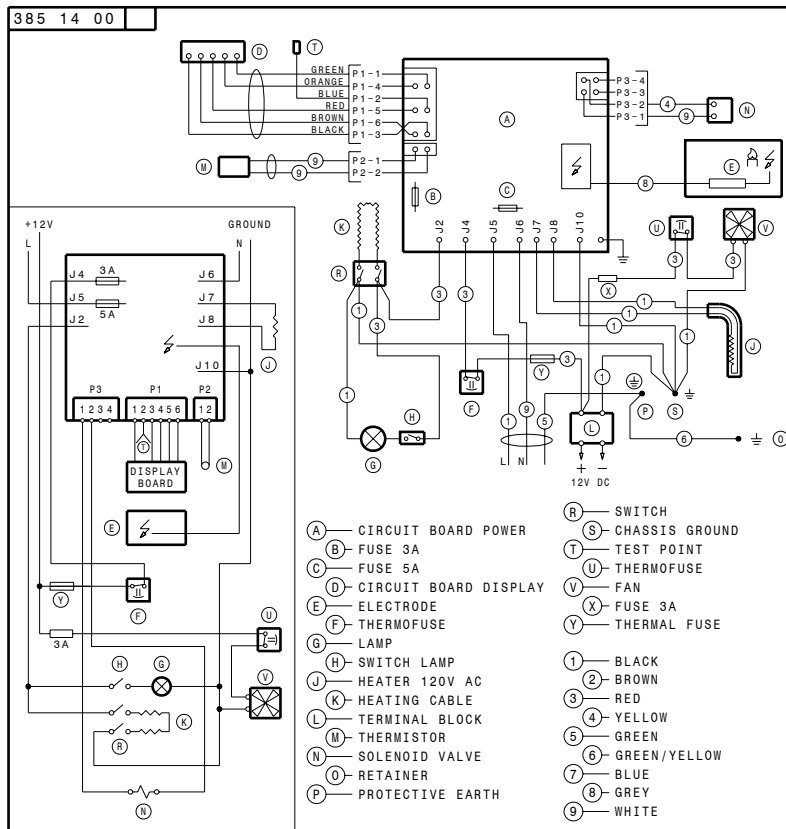

APPENDIX E - WIRING DIAGRAMS

DM2663

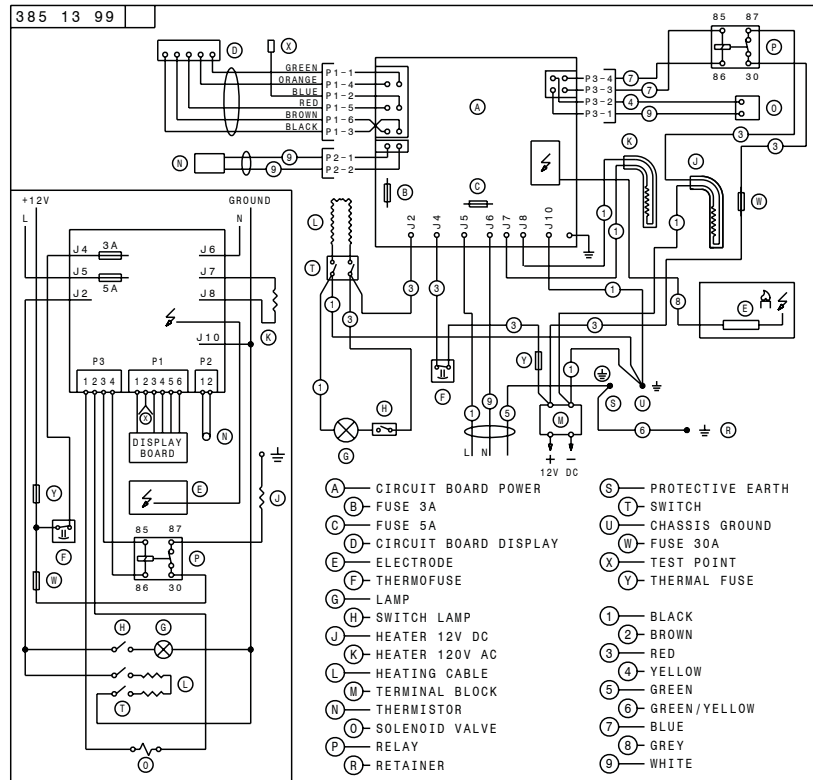

DM3862

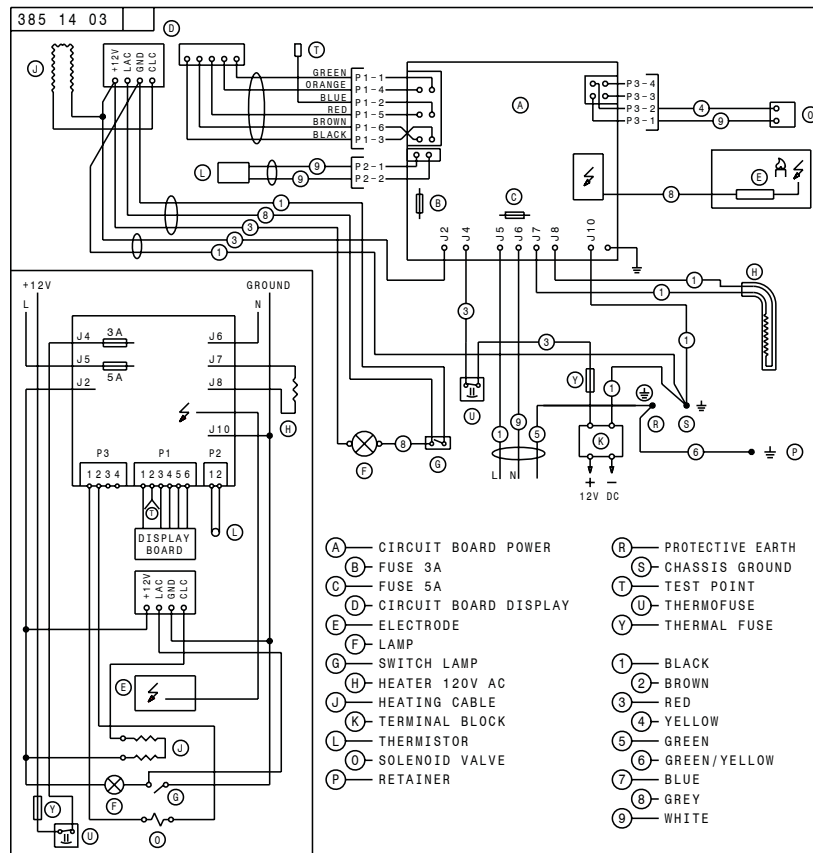

APPENDIX E - WIRING DIAGRAMS

NDM1062 MODEL EQUIPPED WITH STAINLESS STEEL DOORS

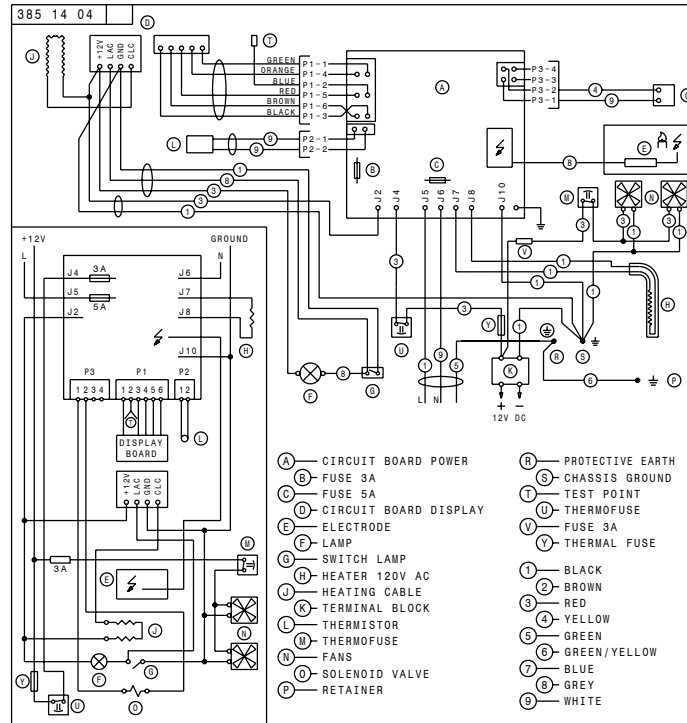

MODEL EQUIPPED WITH STAINLESS STEEL DOORS AND ICE MAKER

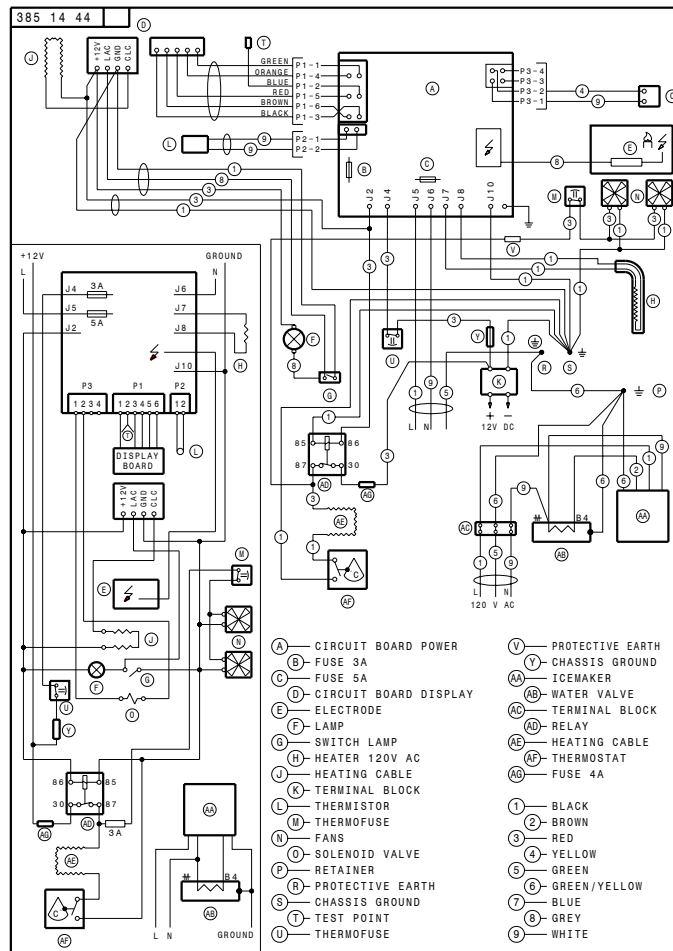

APPENDIX E - WIRING DIAGRAMS

NDM1062

MODEL EQUIPPED WITH DOOR INSERT PANELS

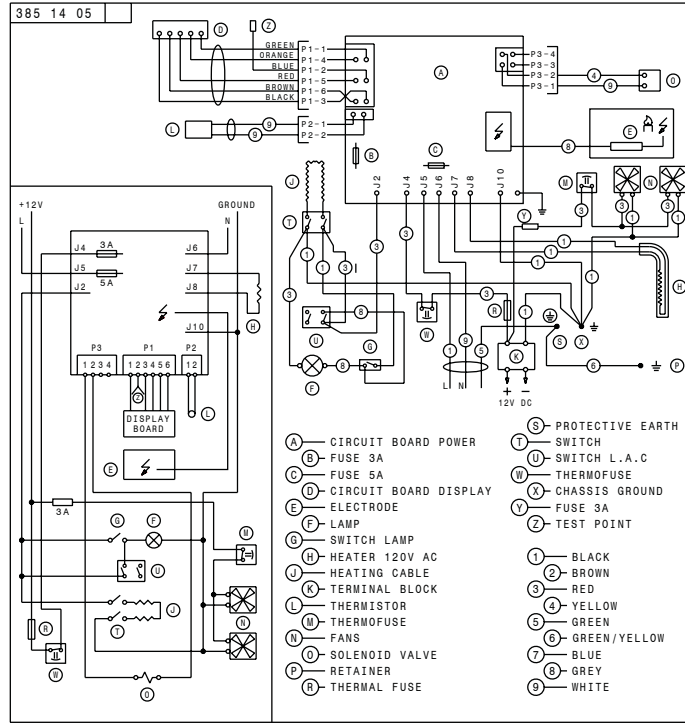

MODEL EQUIPPED WITH DOOR INSERT PANELS AND ICE MAKER

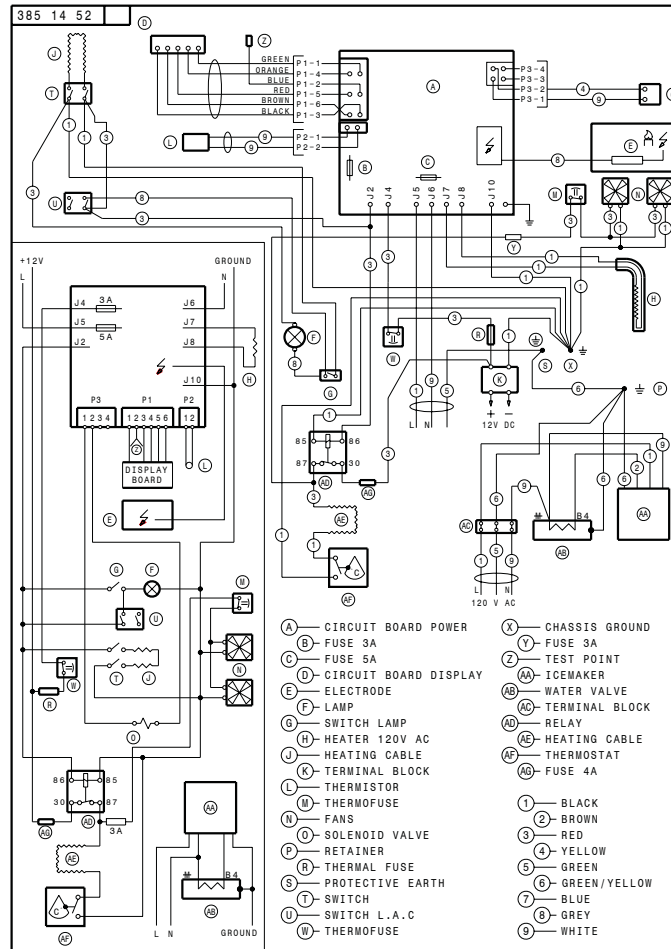

APPENDIX E - WIRING DIAGRAMS

NDR1292

MODEL EQUIPPED WITH STAINLESS STEEL DOORS

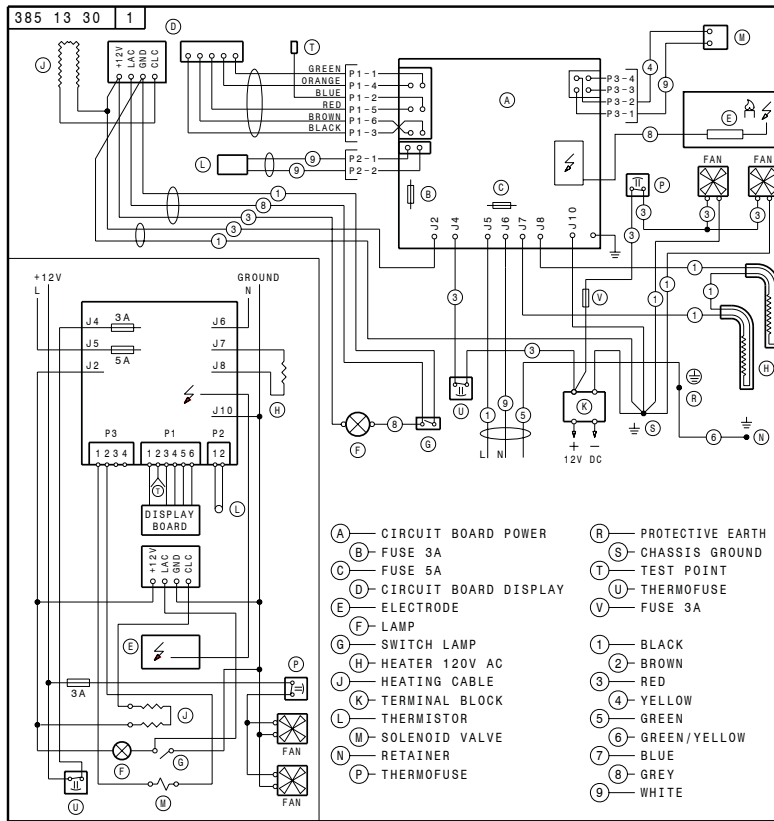

MODEL EQUIPPED WITH DOOR INSERT PANELS

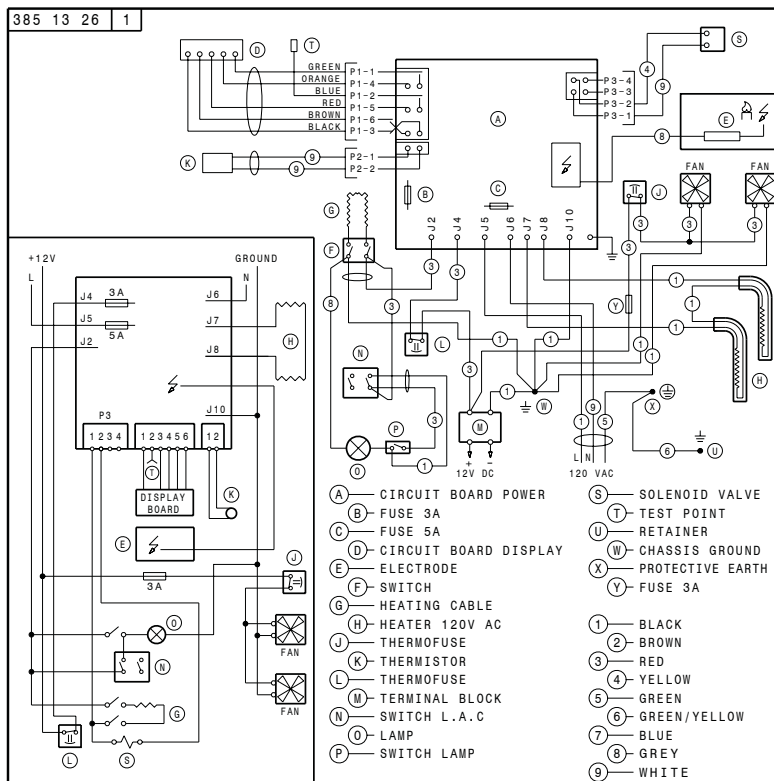

PROTECTION FOR YOUR NEW INVESTMENT

We truly appreciate that you have chosen to purchase a Dometic product for your recreational vehicle and we want to help you protect this wise investment.

We at Dometic back our products with one of the most comprehensive warranties in the industry. Complete the registration card below and mail to us or register your Product on-line at www.edometic.com.



**TIME-DATED
MATERIAL
Please Process
Promptly!**

FIRST
CLASS
POSTAGE
REQUIRED



Dometic Processing Center
2320 Industrial Parkway
Elkhart, IN 46516

Tape
here

■ **WARRANTY VERIFICATION**

Your prompt registration records your right to protection under the terms and conditions of your warranty.

■ **OWNER CONFIRMATION**

Your completed Owner's registration card serves as confirmation of ownership in the event of product damage or theft.

■ **FACTORY COMMUNICATION**

Returning your card of registering on-line guarantees you will receive product information and specials. Leaving your email address below will allow us to communicate with you quickly and efficiently.

■ **3 PLUS 3 SERVICE CONTRACT**

Returning the card below or registering on-line assures you of an invitation to take advantage of an Optional 3 Plus 3 Full Service Contract which allows you to add up to 3 years of additional warranty coverage.



Return the card within **10** days to ensure your:

- WARRANTY VERIFICATION
- FACTORY COMMUNICATION
- OWNER CONFIRMATION
- 3 PLUS 3 SERVICE CONTRACT

Fold here. Close with tape.

IMPORTANT:
Return Within
10 days



Owner's Registration Card

Registering your product is an essential step to ensure that you receive all the benefits you are entitled to as a DOMETIC customer. Complete the information below and mail to us or register on-line at www.edometic.com.

Be sure to include your email address so that we can communicate with you quickly and efficiently. Your address will remain confidential and will not be distribute to third parties.

Name

Address

City Stat/Prov.

Date of Purchase Zip/Postal Code
MO DAY YEAR

Email Address

REFRIGERATOR MODEL NUMBER	SERIAL NUMBER
---------------------------	---------------

TO THE INSTALLER
 PLEASE AFFIX THESE INSTRUCTIONS
 TO THE REFRIGERATOR
 —
TO THE CONSUMER
 PLEASE RETAIN THESE INSTRUCTIONS
 FOR FUTURE REFERENCE